

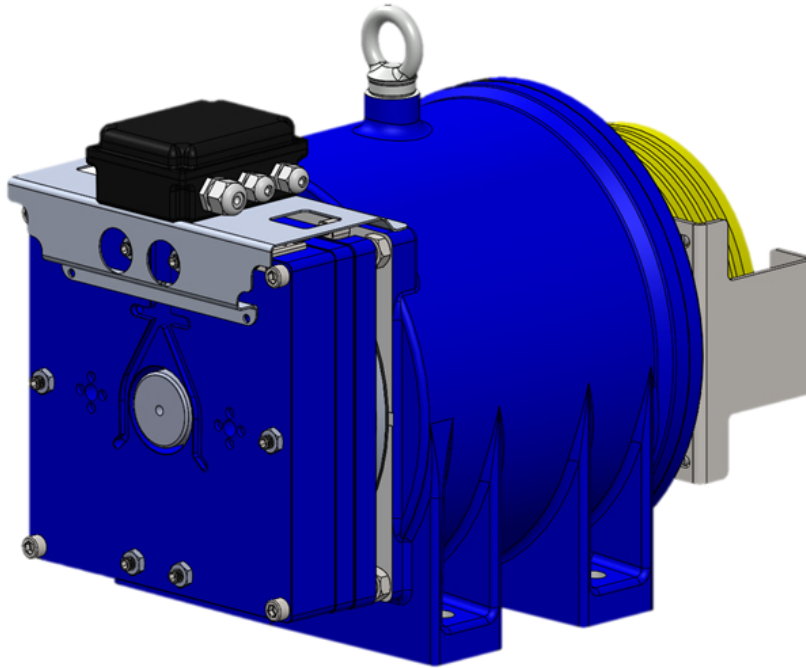

# *OWNER'S HANDBOOK FOR BRAKE*



*The present publication has been written for gearboxes complying with EN 81-20:2020. standards.*

---



*All reproduction rights for the following catalogue are reserved by: **AKIŞ ELEVATOR***

*The text and numerical system shall not be used in other printed matter or translated either partially or entirely without the authorization from **AKIŞ ELEVATOR***

***Note: The descriptions and illustrations supplied here do not express or imply a warranty.***

***AKIŞ ELEVATOR reserves the right to make any modifications it retains necessary at any time.***

*All rights reserved by **AKIŞ ELEVATOR***

## Index

|   |    |
|---|----|
| <b>1. SAFETY INFORMATION</b>  | 2  |
| <b>2. EXCLUSION OF LIABILITY AND WARRANTY</b>   | 2  |
| <b>3. REFERENCE STANDARDS AND DIRECTIVES</b>  | 3  |
| <b>4. PURPOSE AND SCOPE</b>   | 3  |
| <b>5. GENERAL TECHNICAL INFORMATION</b>   | 3  |
| <b>5.1. List of brake components</b>  | 3  |
| 5.1.1. Reference drawings for brake AEMF1 - AEMF2 - AEMF7 - AEMF8   | 3  |
| 5.1.2. Reference drawings for brake AEMF3 - AEMF4 - AEM9 - AEMF10   | 5  |
| 5.1.3. Reference drawings for brake AEMF5 - AEMF11  | 6  |
| 5.1.4. Reference drawings for brake AEMF6 - AEMF12  | 7  |
| <b>5.2. Technical data – physical characteristics</b>   | 8  |
| <b>5.3. Usage limitations</b>   | 8  |
| <b>5.4. Information provided on data plate</b>  | 9  |
| <b>6. OPERATION OF THE BRAKE</b>  | 9  |
| <b>7. TECHNICAL DATA – ELECTRICAL CHARACTERISTICS</b>   | 9  |
| 7.1. Power supply voltage   | 9  |
| 7.2. Electrical diagrams and connections  | 11 |
| 7.3. Microswitches  | 12 |
| <b>8. OPERATIONS NECESSARY BEFORE USING FOR THE FIRST TIME</b>  | 12 |
| 8.1. Unseizing the friction material after a prolonged period with the brake not in use                     | 12 |
| <b>9. INSTRUCTIONS FOR ROUTINE MAINTENANCE</b>  | 13 |
| 9.1. Measuring the air gap  | 14 |
| 9.2. Testing brake aperture   | 14 |
| 9.3. Checking state of brake discs after emergency braking  | 14 |
| <b>10. INSTRUCTIONS FOR EXTRAORDINARY MAINTENANCE</b>   | 14 |
| 10.1. Instructions for adjusting air gap  | 14 |
| 10.2. Replacing brake assembly on machine, or replacing brake discs   | 15 |
| 10.3. Adjusting the microswitches   | 16 |
| <b>11. EMERGENCY PROCEDURE: MANUAL BRAKE RELEASE</b>  | 16 |
| 11.1. Manual brake release procedure with release screws (standard version)                                 | 16 |
| 11.2. Manual brake release procedure with release levers (optional)   | 17 |
| <b>12. THE BRAKE AS A SYSTEM PROTECTING AGAINST UNCONTROLLED MOVEMENT OF THE CAR</b>                        | 17 |
| 12.1. Introduction  | 17 |
| 12.2. Definition of key parameters required by applicable standard/directive for intended application       | 17 |
| 12.3. Interfacing instructions  | 17 |
| 12.4. Uncontrolled car movement detector  | 17 |
| 12.5. Control panel   | 18 |
| 12.6. Cutting off electrical power supply to brake  | 18 |
| 12.7. Monitoring functions for microswitches (for usage as service / emergency brakes on gearless machines) | 18 |
| <b>13. END OF LIFE SCRAPPING</b>  | 18 |
| <b>14. FAQ</b>  | 18 |
| <b>ANNEXE A HOW TO ADJUST AIR GAP IN BRAKES AEMFX</b>   | 19 |
| <b>ANNEXE B HOW TO REPLACE BRAKEDISC AEMFX</b>  | 20 |
| <b>ANNEXE C HOW TO ADJUST THE NOISE BRAKES AEMFX</b>  | 25 |
| <b>ANNEXE D MANUAL BRAKE RELEASE OPERATION WITH SCREWS</b>  | 27 |
| <b>ANNEXE E HOW TO FIT RELEASE LEVERS - MANUAL BRAKE RELEASE OPERATION WITH RELEASE LEVERS ANHANG</b>       | 29 |

## 1 - SAFETY INFORMATION

Read this use and maintenance manual before carrying out any work on the brake.

This manual contains important information for preventing personal injury and damage to the product or other products connected to the product itself.

**IMPORTANT! THIS USE AND MAINTENANCE MANUAL MUST BE KEPT FOR FUTURE REFERENCE FOR AT LEAST THE ENTIRE LIFESPAN OF THE BRAKE PRODUCT IT IS ASSOCIATED WITH.**



### ATTENTION!

To prevent the risk of personal injury or damage to the machine, only specialised and suitably trained personnel may work on this device.

Improper usage of the brake may be dangerous.



### ELECTRIC SHOCK HAZARD!

- This device is electrically powered. Always observe the safety precautions and follow the operational instructions for assembly contained in this document.
- To prevent the risk of fire or electrical discharge, do not expose this device to rain or water. Do not touch the device if you are wet.



Before starting any work on the device, disconnect electrical power by turning off the main switch on the control panel. Do not disconnect the terminals of the device while the brake is electrically powered.

### IMPORTANT WARNINGS

- The device must be operated correctly in accordance with the technical data and other annexed data (data plate specifications and technical information). The device must receive electrical power with the correct specifications in accordance with the information provided on the data plate.
- Check the condition of the device before connecting it to the electrical power supply or putting the device into service.
- Do not install the device if any defects or malfunctions are noted.
- Allow adequate clear space around the brake to permit maintenance to be carried out comfortably when necessary;
- The values indicated in this catalogue have been tested in the factory. However, these parameters may vary in relation to the effective ambient conditions in which the device is used.
- The installation site, the amount of energy dissipated through friction, dynamic behaviour under braking, wear and environmental conditions may influence the performance of the brake. Check that the device works correctly before putting it into service.



### ATTENTION!

Keep the installation area of the device clean.

Oil, grease and water may severely compromise the operation of the brake and reduce braking torque.

## 2 - EXCLUSION OF LIABILITY AND WARRANTIES

The information and technical data contained in this use and maintenance manual were correct and up to date as of the date of publication, and may be subject to subsequent modification without prior warning.

Claims and complaints regarding brakes made on the basis of information contained in newer versions of this manual issued after the original purchase of the brakes themselves will not be accepted.

The manufacturer cannot be held responsible for faults or defects in the following cases:

- If the conditions for installation and general usage contained in this use and maintenance manual have not been read and observed correctly;
- In case of improper use of the brake;
- In case of modification of the original components of the unit, and of the brake itself, made without prior authorisation from **Akiş Elevator**;
- In case of usage in conditions deemed unsuitable;
- In case of usage without due care and attention.

Any visible defects, damage attributable to transport or missing components of the brake unit must be reported immediately to the technical support service of **Akiş Elevator**. Failure to do so will render the warranty null and void. The statutory warranties in effect in EC nations apply.

## 3 - REFERENCE STANDARDS AND DIRECTIVES

All brakes are compliant with the requirements of the standards and directives cited in this use and maintenance manual

### EU DIRECTIVES:

- Machinery directive: 2006/42/EC
- Electromagnetic compatibility directive: 2014/30/EU
- Lifts directive: 2014/33/EU

### UK STATUTORY INSTRUMENT:

- Supply of Machinery Regulation: 2008 No. 1597
- Electromagnetic Compatibility Regulation: 2016 No. 1091
- Lift Regulation: 2016 No. 1093

### STANDARDS:

- Reference standards: EN 81-20:2020  
EN 81-50:2020
- Reference EMC: EN 12015:2020  
EN 12016:2013

### STANDARDS UK

- BS EN 81-20:2020
- BS EN 81-50:2020
- BS EN 12015:2020
- BS EN 12016:2013

### CERTIFICATION:

| Brake | Notified body     | Number |
|-------|-------------------|--------|
| AEMF  | LIFTINSTITUUT B.V | 0400   |
| DEMF  | LIFTINSTITUUT B.V | 0400   |

| Certificate number    |
|-----------------------|
| NL 16-400-1002-182-06 |
| NL 13-400-1002-182-02 |



## 4 - PURPOSE AND SCOPE

The products described in this manual are frontal disc brakes for use as holding systems for suspended loads, and intended for lift installations in particular. The brake immobilises all the moving parts of the lift system when the car is parked at a floor. The brakes are also designed to function as a safety brake, in other terms as a device protecting against overspeed while the lift is ascending and uncontrolled movements of the car when the doors are open.

## 5 - GENERAL TECHNICAL INFORMATION

### 5.1 List of brake components

|    |   |    |                              |
|----|---|----|------------------------------|
| 1  | Primary pressure plate                  | 19 | Microswitch actuator plate   |
| 2  | Fastener screw                          | 20 | Microswitch mount            |
| 3  | Coil                                    | 21 | Release lever fastener screw |
| 4  | Coil housing                            | 22 | Release lever                |
| 5  | Thrust springs                          | 23 | Return spring                |
| 6  | Asymmetric brake disc                   | 24 | Mobile block                 |
| 7  | Machine casing                          | 25 | Spring pins                  |
| 8  | Motor shaft/splined hub                 | 26 | Release nut                  |
| 9  | Coil armature                           | 27 | Fastener screw nut           |
| 10 | Release screw                           | 28 | Open and wrenches            |
| 11 | Calibrated screw of main pressure plate | 29 | Allen wrenches               |
| 12 | Microswitch adjustment nut              | 30 | Screwdriver                  |
| 13 | Microswitch adjustment set screw/dowel  | 31 | Feeler gauge                 |
| 14 | O-ring on spacer                        |    |                              |
| 15 | Washer                                  |    |                              |
| 16 | Screw fastening microswitch onto mount  |    |                              |
| 17 | Microswitch mount fastener screw        |    |                              |
| 18 | Microswitch                             |    |                              |

### 5.1.1 Reference drawings for brake AEMF1-AEMF2-AEMF7-AEMF8

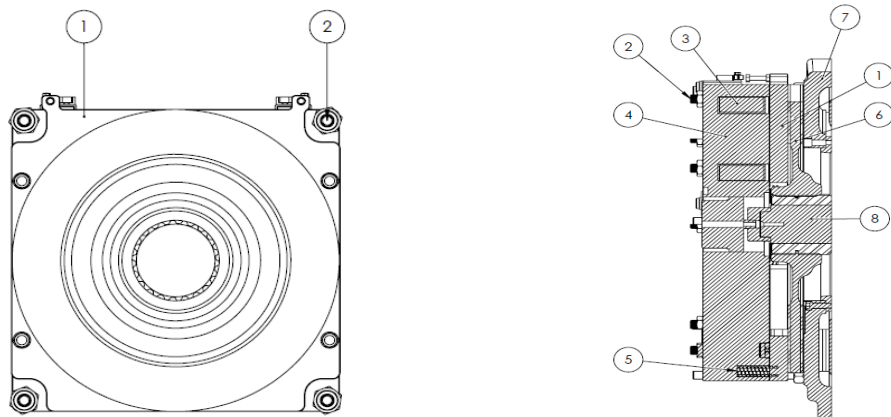

Figure 1. Front view and lateral cross section view of brakes AEMF1-2-7-8

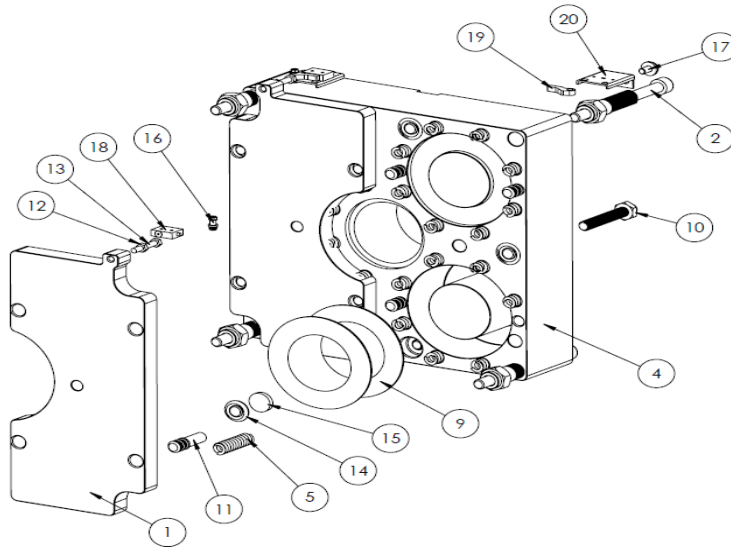

Figure 1a. Exploded view of coil assembly of brakes AEMF1-2-7-8

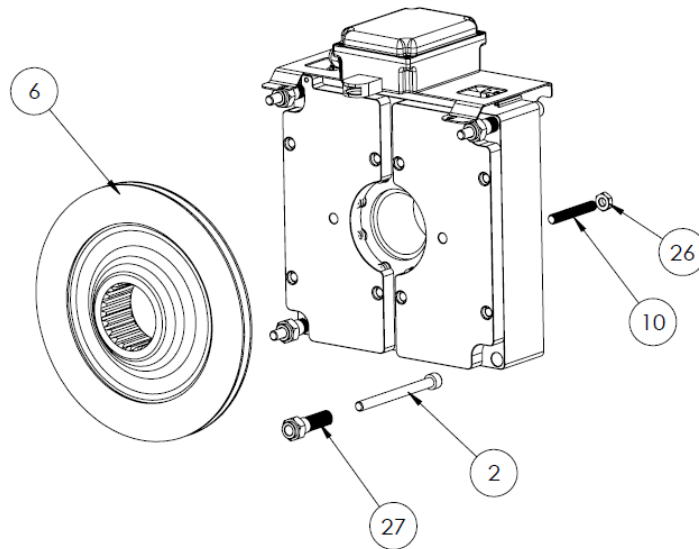

Figure 1b. Exploded view of brake AEMF1-2-7-8

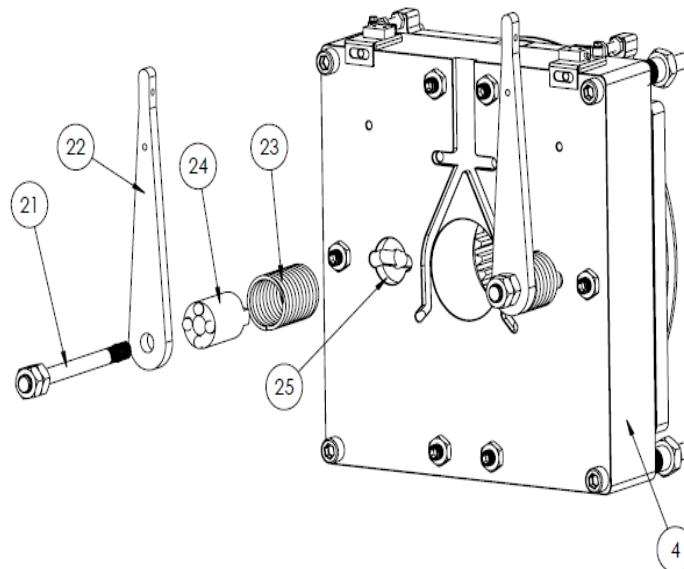

Figure 1c. Exploded view of manual release lever assembly of brake AEMF1-2-7-8

5.1.2 Reference drawings for brake AEMF3-AEMF4-AEMF9-AEMF10

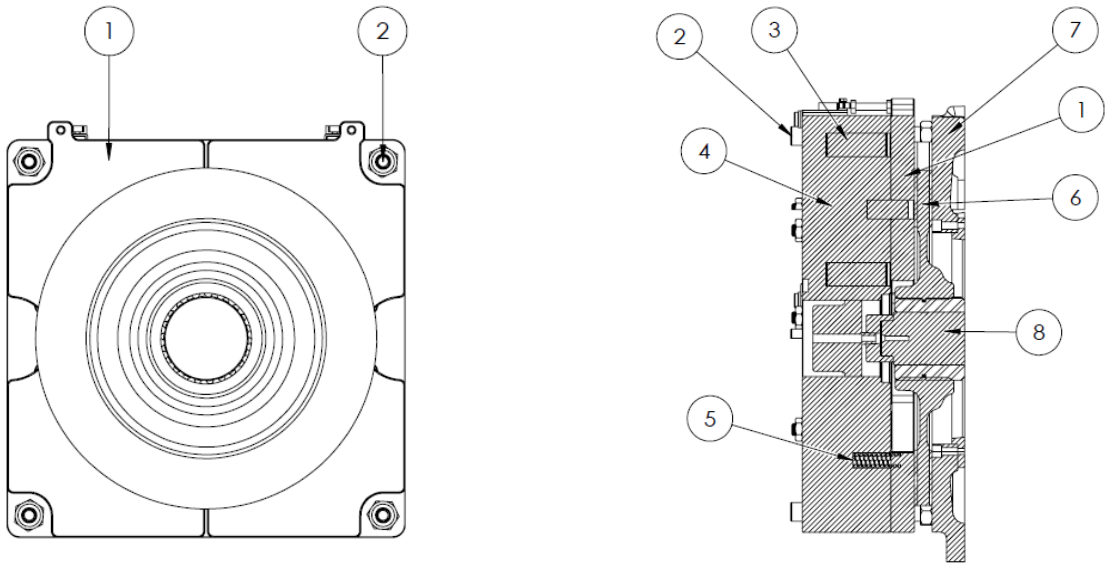

Figure 2. Front view and lateral cross section view of brakes AEMF3-4-9-10

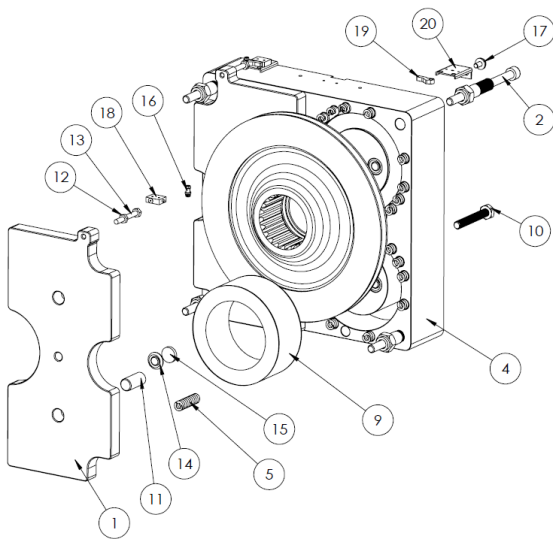

Figure 2a. Exploded view of coil assembly of brakes AEMF3-4-9-10

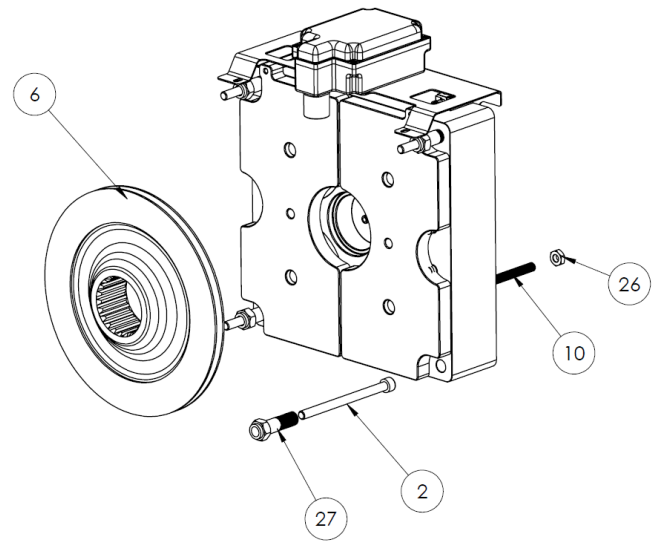

Figure 2b. Exploded view of brake AEMF3-4-9-10

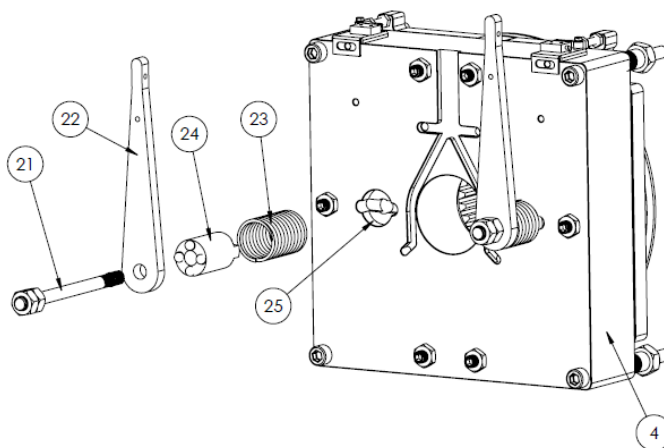

Figure 2c. Exploded view of manual release lever assembly of brake AEMF3-4-9-10

5.1.3 Reference drawings for brake AEMF5-AEMF11

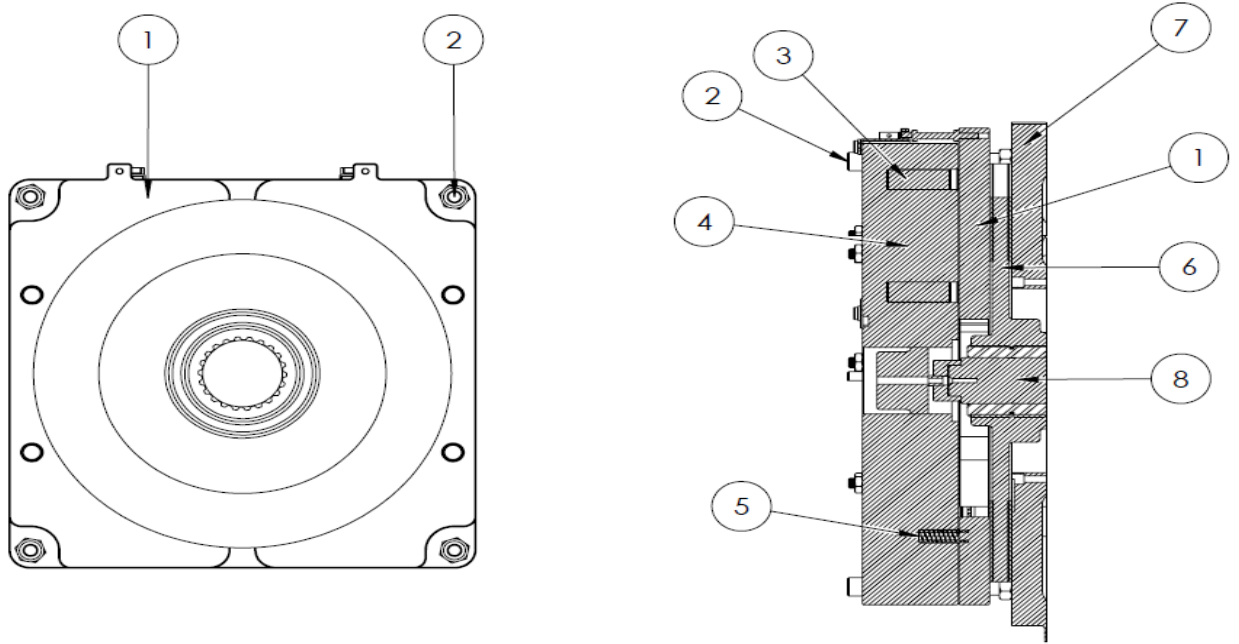

Figure 3. Front view and lateral cross section view of brakes AEMF5-11

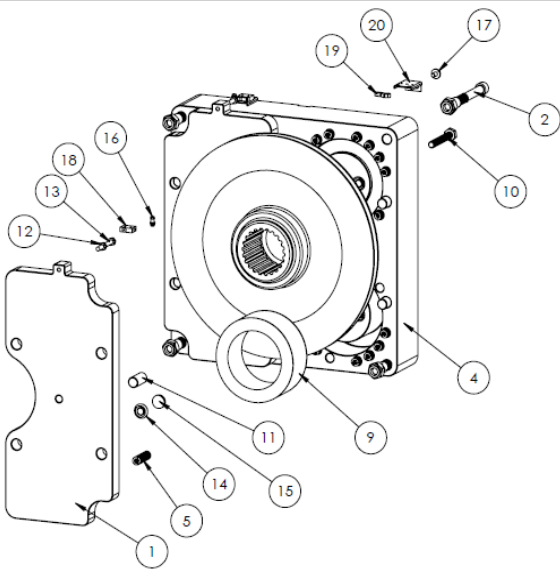

Figure 3a. Exploded view of coil assembly of brakes AEMF5-11

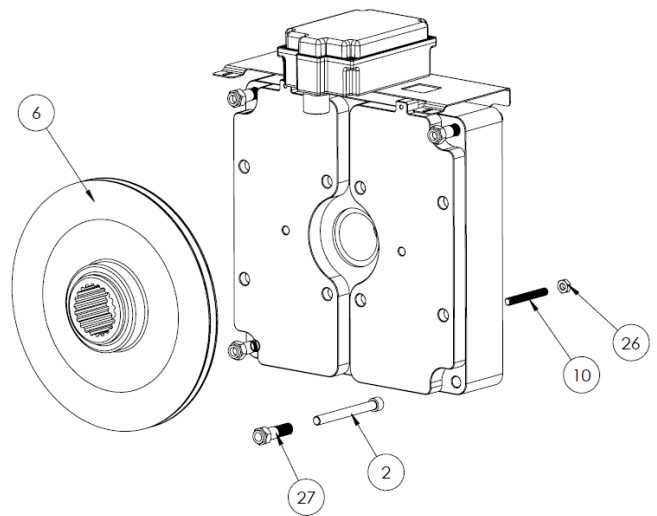

Figure 3b. Exploded view of brake AEMF5-11

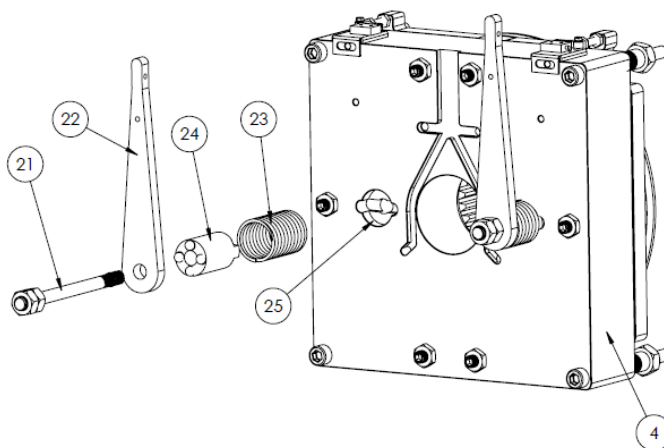

Figure 3c. Exploded view of manual release lever assembly of brake AEMF5-11

5.1.4 Reference drawings for brake AEMF6-AEMF12

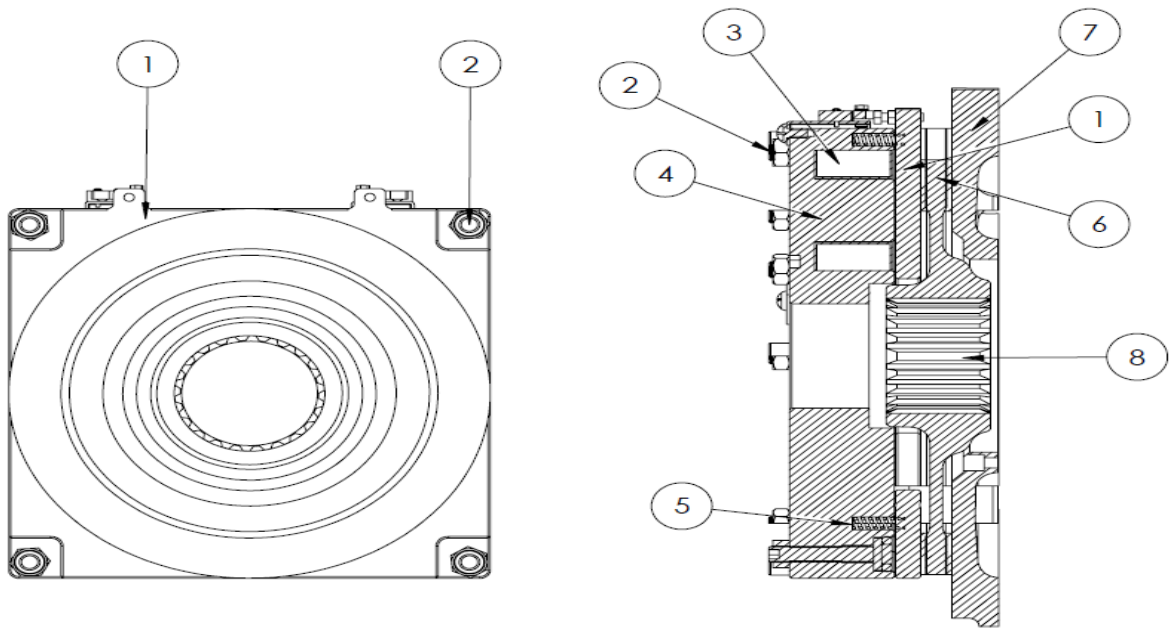

Figure 4. Front view and lateral cross section view of brakes AEMF6-12

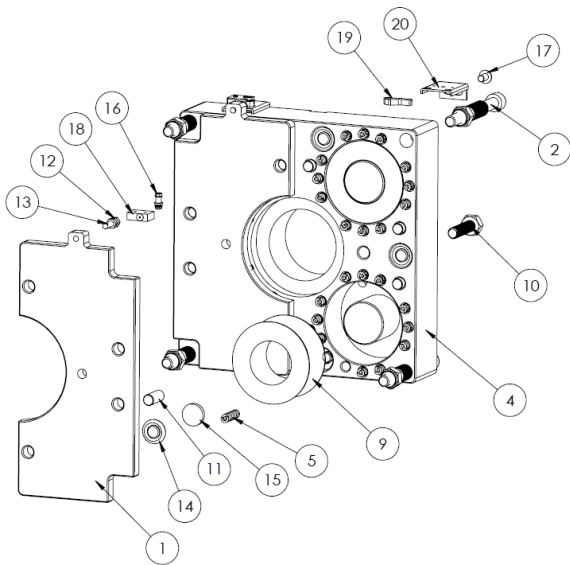

Figure 4a. Exploded view of coil assembly of brakes AEMF6-12

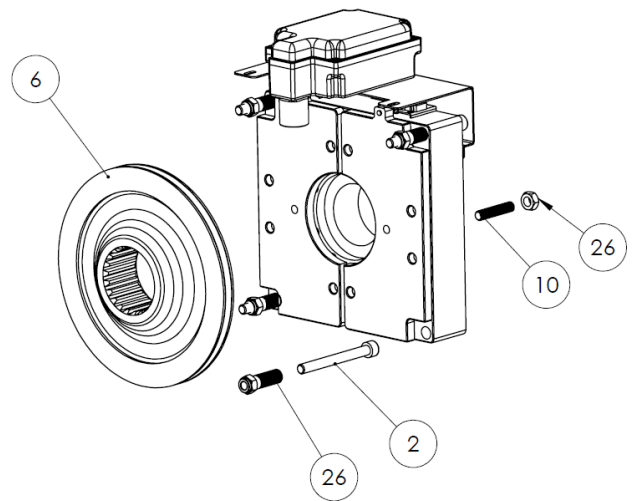

Figure 4b. Exploded view of brake AEMF6-12

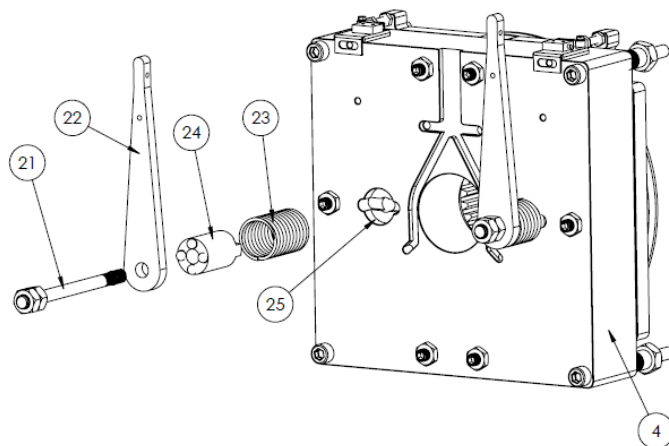

Figure 4c. Exploded view of manual release lever assembly of brake AEMF6-12

### 5.2 Technical data – physical characteristics

In relation to the required braking torque, the AEMF1 and AEMF2 front brake discs(6) and the type of coil housing(4) used are the same size; the number of compression springs(5) used is different. AEMF3 and AEMF4 front brake discs(6) and the type of coil housing(4) used are the same size; the number of compression springs(5) used is different. AEMF7 and AEMF8 front brake discs(6) and the type of coil housing(4) used are the same size; the number of compression springs(5) used is different. AEMF9 and AEMF10 front brake discs(6) and the type of coil housing(4) used are the same size; the number of compression springs(5) used is different.

In relation to the required braking torque, the AEMF5 and AEMF11 front brake discs(6) are the same in size, the number of thrust springs(5) and the type of coil housing(4) used are the same, different from the dimensions of the other brake types.

In relation to the required braking torque, the AEMF6 and AEMF12 front brake discs(6) are the same in size, the number of thrust springs(5) and the type of coil housing(4) used are the same, different from the dimensions of the other brake types.

**Table 1. Performance and characteristics of AEMFX Brakes**

| Brake  | Spring | Voltage | Maximum Speed (rpm) | Brake Lining (ø) | Max. Air Gap (mm) | Nominal Torque (Nm) | T <sub>10</sub> (ms) | T <sub>90</sub> (ms) |
|--------|--------|---------|---------------------|------------------|-------------------|---------------------|----------------------|----------------------|
| AEMF1  | 4*6    | 197/110 | 615                 | 270              | 0,45±0,5          | 2*550               | 40                   | 320                  |
| AEMF2  | 4*7    | 197/110 | 615                 | 270              | 0,45±0,5          | 2*650               | 40                   | 360                  |
| AEMF3  | 4*10   | 197/110 | 342                 | 270              | 0,40±0,5          | 2*750               | 40                   | 450                  |
| AEMF4  | 4*12   | 197/110 | 342                 | 270              | 0,40±0,5          | 2*875               | 20                   | 450                  |
| AEMF5  | 4*12   | 197/110 | 342                 | 340              | 0,50±0,5          | 2*1100              | 40                   | 480                  |
| AEMF6  | 4*4    | 197/110 | 615                 | 230              | 0,40±0,5          | 2*220               | 25                   | 280                  |
| AEMF7  | 4*6    | 110/70  | 615                 | 270              | 0,45±0,5          | 2*550               | 40                   | 340                  |
| AEMF8  | 4*7    | 110/70  | 615                 | 270              | 0,45±0,5          | 2*650               | 40                   | 360                  |
| AEMF9  | 4*10   | 110/70  | 342                 | 270              | 0,40±0,5          | 2*750               | 40                   | 440                  |
| AEMF10 | 4*12   | 110/70  | 342                 | 270              | 0,40±0,5          | 2*875               | 30                   | 450                  |
| AEMF11 | 4*12   | 110/70  | 342                 | 340              | 0,50±0,5          | 2*1100              | 40                   | 480                  |
| AEMF12 | 4*4    | 110/70  | 615                 | 230              | 0,40±0,5          | 2*220               | 25                   | 280                  |

The performance characteristics and weight and the axial measurement of the braking device alone are indicated in the following tables.

Response times are defined as follows:

t<sub>10</sub> = time taken by brake to produce 10% of the certified minimum dynamic torque

t<sub>90</sub> = time taken by brake to produce 90% of the certified minimum dynamic torque

### 5.3 Usage limitations

In accordance with paragraph 0.4.16 of the standard EN 81-20:2014, ambient temperature is defined as temperatures between +5°C and +40°C. The components of the electromagnet are all Class B components, with a maximum permissible operating temperature of 130°C.

Condensation and temperatures of 0°C or lower will reduce the performance of the friction materials and may reduce braking torque. The user is responsible for ensuring that the installation is only operated within the permitted ambient temperature range; if it is not possible to ensure these conditions, adequate measures must be implemented (e.g.: thermostat controlled heaters, forced ventilation systems etc.).

The brakes are have an ingress protection rating of IP 10, ensuring protection against the ingress of solid foreign objects measuring over 50 mm. The brakes are not equipped with any protection against the ingress of water.

The coil within the brake has an ingress protection rating of IP 41, ensuring protection against objects measuring 1 mm in size and greater, and against rain. The brakes are protected against corrosion.



### 5.4 Information provided on data plate

Definitions of symbols used on data plates:

- Serial No:** Motor and Brake Serial Number
- Certificate No:** Brakes Certification
- Type:** Brake Mode
- Braking Power:** Brake Rated Power
- Braking Voltage:** Brake Rated Voltage (Take Up and Hold)
- Braking Torque:** Brake Rated Torque

The data plate also bears the identification details of the manufacturer, the CE marking and the number of the notified body which certified the brake. To facilitate traceability, the data plate also includes a QR-code with the following information: Type, Serial No, Name of manufacturer and Simplified address.



Figure 5. Example of data plate with nominal characteristics of brake.

## 6 - OPERATION OF THE BRAKE

The brakes cited in this use and maintenance manual are frontal brake discs (Figure 1, Figure 2, Figure 3 and Figure 4), in which the main pressure plate is split into two halves, with each half operating independently of the other to ensure the redundancy required by paragraph 5.9.2.2.2.1 of the standard EN 81-20:2014 concerning usage as an electromechanical brake (and not as ascending overspeed protection).

The brake is fastened to the casing of the machine (7) with screws (2), each one of which is installed in a spacer (29) screwed into the casing itself. The brake is fastened with screws with a tensile strength class of 8.8, in the quantities and with the tightening torques specified in Table 2.

Table 2. Tighten torques/number of brake fastener screws.

| TIGHTENING TORQUE FOR SCREWS |               |             |                       |
|------------------------------|---------------|-------------|-----------------------|
| Brake                        | No. Of Screws | Thread      | Tightening Torque(Nm) |
| AEMF1                        | 4             | M10x120x1,5 | 50                    |
| AEMF2                        | 4             | M10x120x1,5 | 50                    |
| AEMF3                        | 4             | M10x130x1,5 | 50                    |
| AEMF4                        | 4             | M10x140x1,5 | 50                    |
| AEMF5                        | 4             | M10x140x1,5 | 50                    |
| AEMF6                        | 4             | M10x100x1,5 | 50                    |
| AEMF7                        | 4             | M10x120x1,5 | 50                    |
| AEMF8                        | 4             | M10x120x1,5 | 50                    |
| AEMF9                        | 4             | M10x130x1,5 | 50                    |
| AEMF10                       | 4             | M10x140x1,5 | 50                    |
| AEMF11                       | 4             | M10x140x1,5 | 50                    |
| AEMF12                       | 4             | M10x100x1,5 | 50                    |

The outer surfaces of the spacers have small grooves in which O-rings (14) are installed to attenuate the impact force when the device is braking. The operating principle of the different brake types is the same. In the case of single disc brakes, the braking torque is obtained as a result of the friction force generated between the brake disc (6), the split main pressure plate (1) and the casing of the machine (7). This friction force is generated by a thrust force exerted uniformly by the thrust springs (5) against the main pressure plate (see Table 1 for the number of springs).

Each pressure plate (1) is immobilised radially to prevent rotation, but can slide axially to eliminate the clearance when braking. The air gap of the brake is preset in the factory. The brake discs (6), compressed by the pressure plates (1), are lined with friction material on both sides and are fastened rigidly to the motor shaft (8) via the splined hub, which transmits braking torque to the machine. Each main pressure plate (1) receives the thrust force exerted by the springs (5) directly from the springs themselves.

The two main pressure plates (1) are monitored independently by two microswitches installed on the exterior of the coil housing (4); these microswitches produce an on/off signal. The trigger position of the microswitches is calibrated in the factory by adjusting the set screw/dowel (13) and the adjustment nut (12) appropriately. The brake is released electromagnetically during normal operation or manually in the event of an emergency. The two/four coils (3) are seated in the main casing of the brake in a symmetrical arrangement with the two parts constituting the main pressure plate.

## 7 - TECHNICAL DATA – ELECTRICAL CHARACTERISTICS

### 7.1 Power supply voltage

Tables 3,4,5 and 6 illustrate the electrical characteristics of DFX, DQXY and DGXY brakes at the different rated voltages.

For AK - AKD and S series used AEMFX brakes are capable of operating at the full rated voltage with a maximum duty cycle of 60%.

For VOLPI MRL and MUGEN MRL series used AEMFX brakes are capable of operating at the full rated voltage with a maximum duty cycle of 40%.

For HOMELIFT series used AEMF6 - AEMF12 brakes are capable of operating at the full rated voltage with a maximum duty cycle of 25%.



**Table 3.** Standard electrical characteristics of **AEMF1-2-7-8 Brake.**

| Rated Voltage(V) | Power (W) | Holding Voltage(V) | Pairs Coil Connection Type | Max. Ambient Temp. [°C] |
|------------------|-----------|--------------------|----------------------------|-------------------------|
| 220              | 170       | 125                | Series                     | 40 °C                   |
| 205              |           | 115                | Series                     | 40 °C                   |
| 198              |           | 110                | Series                     | 40 °C                   |
| 190              |           | 105                | Series                     | 40 °C                   |
| 110              |           | 70                 | Parallel                   | 40 °C                   |
| 60               |           | 38                 | Parallel                   | 40 °C                   |
| 48               |           | 31                 | Parallel                   | 40 °C                   |

**Table 4.** Standard electrical characteristics of **AEMF3-9 Brake.**

| Rated Voltage(V) | Power (W) | Holding Voltage(V) | Pairs Coil Connection Type | Max. Ambient Temp. [°C] |
|------------------|-----------|--------------------|----------------------------|-------------------------|
| 220              | 270       | 125                | Parallel                   | 40 °C                   |
| 205              |           | 115                | Parallel                   | 40 °C                   |
| 198              |           | 110                | Parallel                   | 40 °C                   |
| 190              |           | 105                | Parallel                   | 40 °C                   |
| 110              |           | 70                 | Parallel                   | 40 °C                   |
| 60               |           | 38                 | Parallel                   | 40 °C                   |
| 48               |           | 31                 | Parallel                   | 40 °C                   |

**Table 5.** Standard electrical characteristics of **AEMF4-5-10-11 Brake.**

| Rated Voltage(V) | Power (W) | Holding Voltage(V) | Pairs Coil Connection Type | Max. Ambient Temp. [°C] |
|------------------|-----------|--------------------|----------------------------|-------------------------|
| 220              | 370       | 125                | Parallel                   | 40 °C                   |
| 205              |           | 115                | Parallel                   | 40 °C                   |
| 198              |           | 110                | Parallel                   | 40 °C                   |
| 190              |           | 105                | Parallel                   | 40 °C                   |
| 110              |           | 70                 | Parallel                   | 40 °C                   |
| 60               |           | 38                 | Parallel                   | 40 °C                   |
| 48               |           | 31                 | Parallel                   | 40 °C                   |

**Table 6.** Standard electrical characteristics of **AEMF6-12 Brake.**

| Rated Voltage(V) | Power (W) | Holding Voltage(V) | Pairs Coil Connection Type | Max. Ambient Temp. [°C] |
|------------------|-----------|--------------------|----------------------------|-------------------------|
| 220              | 100       | 125                | Series                     | 40 °C                   |
| 205              |           | 115                | Series                     | 40 °C                   |
| 198              |           | 110                | Series                     | 40 °C                   |
| 190              |           | 105                | Series                     | 40 °C                   |
| 110              |           | 70                 | Parallel                   | 40 °C                   |
| 60               |           | 38                 | Parallel                   | 40 °C                   |
| 48               |           | 31                 | Parallel                   | 40 °C                   |

A suitable potentiometer device for adjusting the power supply voltage may be used to apply a reduced holding voltage to the brakes. The holding voltage is indicated in the tables given above. The use of a voltage control potentiometer is recommended to reduce the power supply voltage for installations with very long travels (> 40 m) and limit the possibility of the brake overheating. For any other queries or requirements concerning the power supply voltage for the brake, contact the technical support service of **Akiş Elevator**.

## 7.2 Electrical diagrams and connections

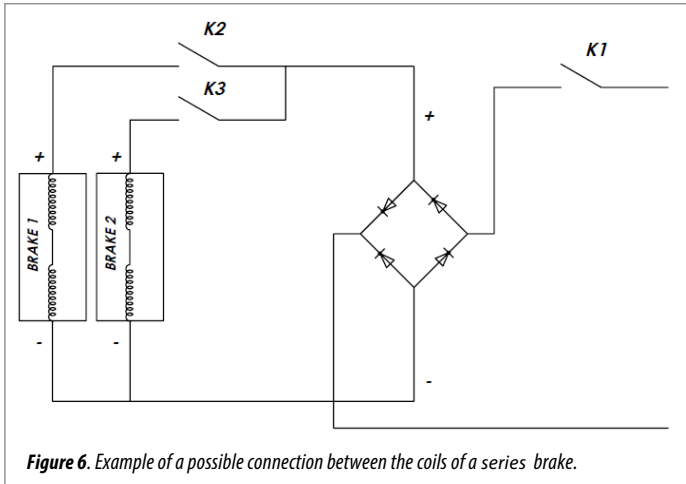

Figure 6. Example of a possible connection between the coils of a series brake.

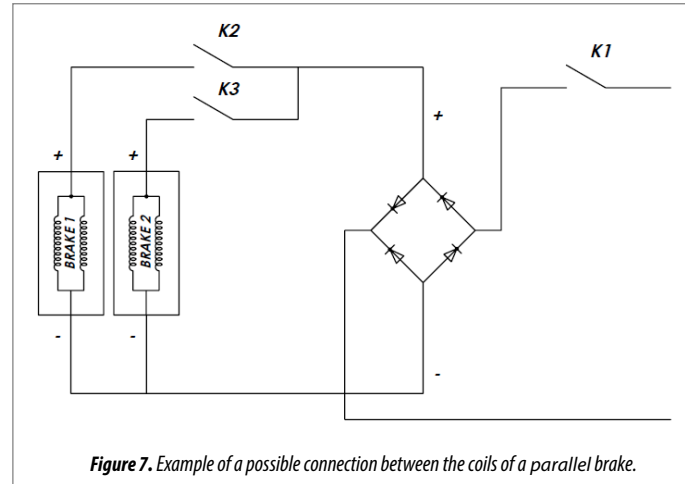

Figure 7. Example of a possible connection between the coils of a parallel brake.

The electrical connections of the coils (3) must be made by qualified personnel. The terminals of the coils and of the microswitch contacts (which are electrically isolated from each other) are connected to specific brake power and control terminals. The brake is powered with direct current (DC) electrical power. The voltage may be supplied via a full wave diode bridge rectifier (not included in material supplied). A principal electrical scheme is illustrated in Figures 6 and 7 (evaluate the applicability of the scheme in consideration of applicable legislation and standards).

The three switches - K1 on the AC power branch, and K2 and K3 on the DC power branch - improve the operating conditions of the coil controller contacts and make the operation of the brake itself more comfortable. To activate the brake, the electrical power supply must be cut off as follows:

- during **normal operation**, electrical power is cut off on the AC side by opening switch K1 only. The bridge rectifier and the brake coils function as an arc suppressor system (in accordance with paragraph 5.9.2.2.2.3 of the standard EN 81-20:2014), preventing additional delay in breaking electrical power feed. This allows the brake to operate more quietly.
- in the case of **emergency operation**, electrical power is cut off on the DC side by opening switches K2 and K3 simultaneously. This shortens the brake application time, ensuring a more rapid response.
- for **periodical testing**, the aperture of one half of the brake may be tested at a time, in accordance with paragraph 5.9.2.2.2.7 of the standard EN 81-20:2014, by closing either K2 or K3.

The brake is mounted on the same isostatic shaft as the traction sheave.

The terminals of the brake are equipped with specific connectors to facilitate connection. Figure 9 illustrates the series electrical wiring diagram for connecting AEMFX brakes, while Figure 10 illustrates the parallel electrical wiring diagram for connecting the AEMFX brake.

Power is supplied to the + and – terminals, as the coils are powered in parallel and series. Resistors and diodes to protect the coils themselves (**dotted line - Figure 9 and Figure 10**) may be installed between the (+) and (-) terminals.

Extension cables for powering the brake and managing the microswitch signals are available as accessories.

During normal operation, the brake must be powered with the rated voltage applied to both (+) wires in parallel. For the test, power one (+) terminal at a time.

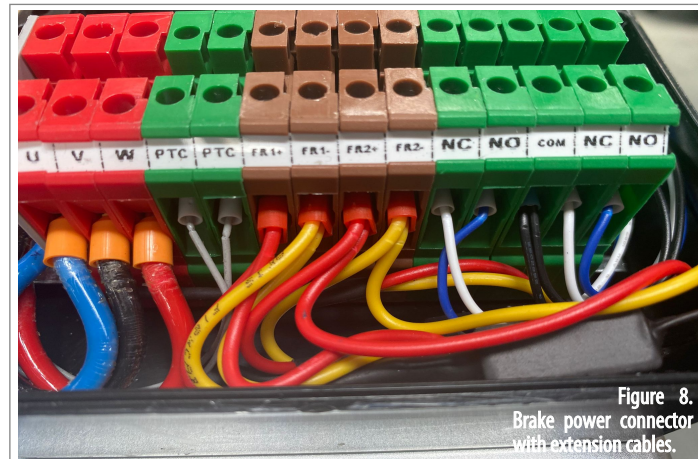
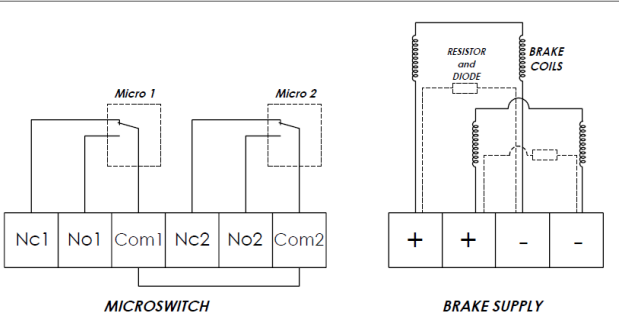

Figure 8. Brake power connector with extension cables.



### IMPORTANT!

Both halves of the brake must be powered for normal operation.



| SYMBOL | COLOR   | CONNECTION              |
|--------|---------|-------------------------|
| +      | KIRMIZI | POWER SUPPLY +          |
| -      | SARI    | POWER SUPPLY -          |
| Nc1    | BEYAZ   | NORMALLY CLOSED MICRO 1 |
| No1    | MAVİ    | NORMALLY OPEN MICRO 1   |
| Com1   | SIYAH   | COMMON MICRO 1          |
| Nc2    | BEYAZ   | NORMALLY CLOSED MICRO 2 |
| No2    | MAVİ    | NORMALLY OPEN MICRO 2   |
| Com2   | SIYAH   | COMMON MICRO 2          |

**Figure 9.**  
Electrical wiring diagram for connecting series brakes.

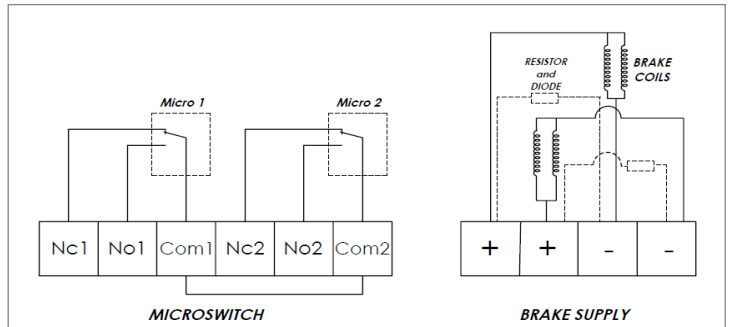

| SYMBOL | COLOR   | CONNECTION              |
|--------|---------|-------------------------|
| +      | KIRMIZI | POWER SUPPLY +          |
| -      | SARI    | POWER SUPPLY -          |
| Nc1    | BEYAZ   | NORMALLY CLOSED MICRO 1 |
| No1    | MAVİ    | NORMALLY OPEN MICRO 1   |
| Com1   | SIYAH   | COMMON MICRO 1          |
| Nc2    | BEYAZ   | NORMALLY CLOSED MICRO 2 |
| No2    | MAVİ    | NORMALLY OPEN MICRO 2   |
| Com2   | SIYAH   | COMMON MICRO 2          |

**Figure 10.**  
Electrical wiring diagram for connecting parallel brake.

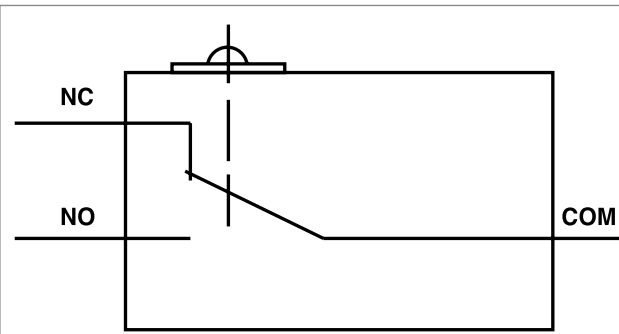

**Figure 11.** Circuit diagram of microswitch installed.

### 7.3 Microswitches

The safety function of the brake is performed by the microswitches. The two microswitches (18) are situated on the exterior of the coil housing and confirm the correct open and closed states of the split main pressure plate (1). Each microswitch has two contacts, one of which normally open (NO) and the other normally closed (NC). When the brake is unpowered, the NC contact is in "ON" state and the NO contact is in "OFF" state.

When the brake is powered, the split main pressure plate (1) is attracted to the coil housing, opening the brake, changing the state of the NC contact to "OFF" and the state of the NO contact to "ON".

The devices and systems for managing the signals produced by each of the microswitches are the responsibility of the user of the machine. The microswitches (18) are pre-calibrated in the factory. However, in case of maintenance work on the device, it is also necessary to check that the microswitches are triggered correctly.

The two microswitches may operate with either direct current or alternating current. The microswitches have an estimated lifespan of one million cycles. However, the effective lifespan is significantly reduced if higher operating voltages and currents are used. The usage limitations are indicated in **Table 7**.

**Table 7.** Electrical usage limitations of microswitches.

|    | Voltage | Current |
|----|---------|---------|
| AC | < 250 V | < 0.5 A |
| DC | < 48 V  | < 0.1 A |

The terminals of the microswitches are connected to the COM, NO and NC terminals, as shown in **Figure 9** and **Figure 10**. In the standard configuration of the brake supplied, the microswitches are connected independently on both brake families. If requested, the microswitches may be connected in parallel.

The states of the microswitches must be monitored by the **CONTROL PANEL**. If one of the pressure plates does not respond as expected for the command signal sent to the brake, any further operation must be disabled and the fault must be signalled. The fault warning signal must remain active until the fault is resolved by qualified personnel. The cause of the fault must be identified and rectified to return the brake to proper working order.

## 8 - OPERATIONS NECESSARY BEFORE USING FOR THE FIRST TIME

### 8.1 Unseizing the friction material after a prolonged period with the brake not in use

If the machine on which the brake is installed remains out of use for prolonged periods of time, the friction material may seize onto the surfaces it is pressed against. This situation may lead to a malfunction of the inverter or brake.



**ATTENTION!**

Before starting any work, take all measures necessary to make the installation and the machine safe in accordance with applicable legislation. Secure all suspended loads safely

In case of repeated alarm conditions relative to the inverter, check that the sheave can turn freely when the brake is opened (electrically or manually). To do so, following the brake aperture/closure test procedure:

- with the machine (or installation) stationary, power the brake with its rated voltage;
- use an ohmmeter to check that the two brake microswitches detect the open state;
- disconnect power to the brake;
- use an ohmmeter to check that the two brake microswitches detect the closed state.

**Notes (relative to use in gearless installations):**

1. if the sheave is not loaded by the ropes, the motor must be rotated manually;
  2. if the machine is installed, movement of the sheave should be induced as a natural consequence of the imbalance between car and the counterweight.
- This procedure must only be carried out if the phases of the stator have been short circuited, in accordance with the instructions given in the use and maintenance manual of the machine.**

If the microswitches do not indicated a fault relative to the aperture/closure of the brake and if the sheave cannot rotate freely when the brake is open, it is very likely that the friction material of the disc has seized onto the surfaces it is pressed against.

**Clearly, the brake release procedure described below requires complete and unimpeded access to the brake. AKIŞ Elevator cannot be held responsible for any consequences where access to the brake is partially impeded or not possible.**

Now carry out the procedure for releasing the seized disc:



**TOOLS NECESSARY:**

- Flat head screwdriver;
- Chisel and plastic mallet;

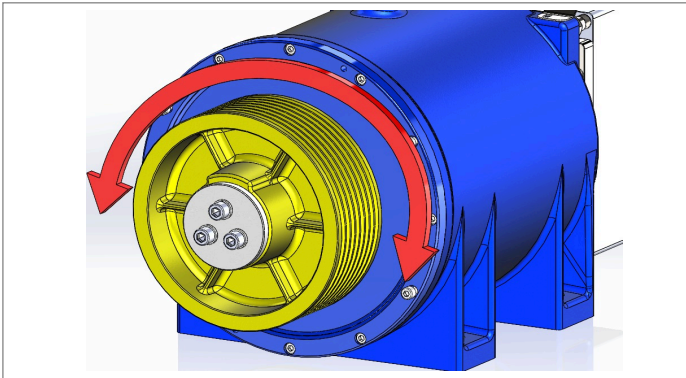
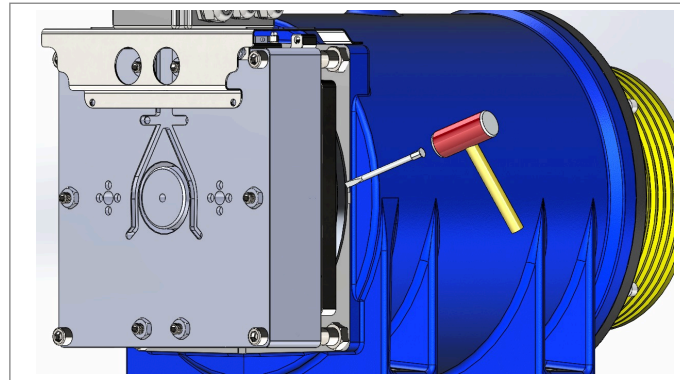
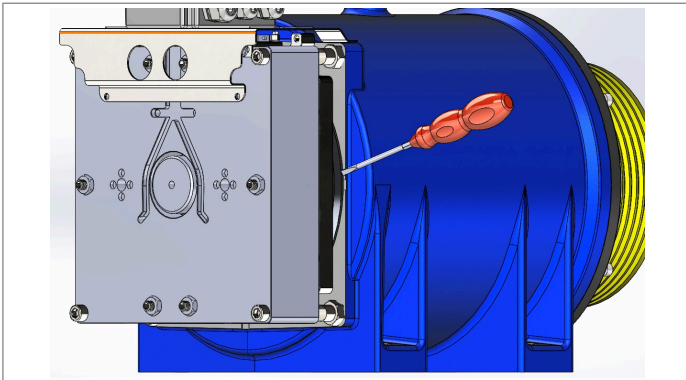

With the brake open, insert the tip of a medium sized flat head screwdriver between the friction material and the casing of the machine: twisting the screwdriver slightly should detach the brake disc from the friction surface. If this does not detach the brake disc, gently tap the aluminium surface of the disc using a plastic mallet and a chisel or the same screwdriver used before, taking care not to damage the surface of the friction material and the surrounding mechanical components.

Manually check that the friction surfaces have been released. With the brake powered electrically, try to rotate the sheave in both directions. If the brake still cannot rotate freely or for any other problems, please contact the after-sales department of **AKIŞ Elevator**.

**9 - INSTRUCTIONS FOR ROUTINE MAINTENANCE**



**ATTENTION!**

Before starting any work, take all measures necessary to make the installation and the machine safe in accordance with applicable legislation.

See **Paragraph 5.1** for the figures illustrating the components involved

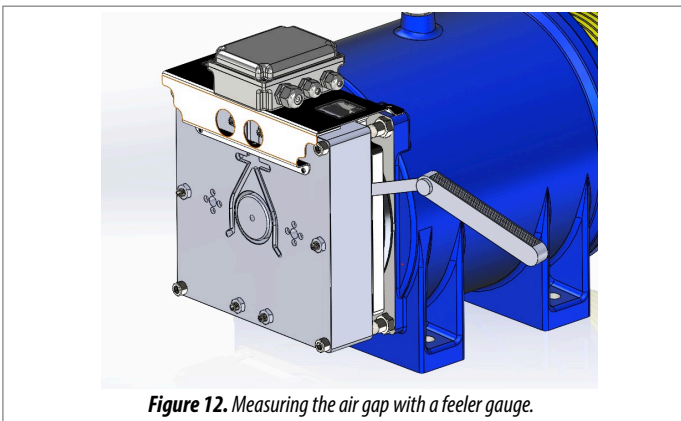

**Figure 12.** Measuring the air gap with a feeler gauge.

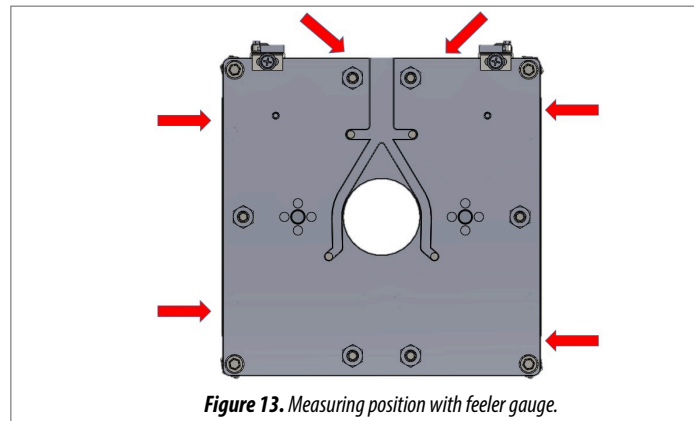

**Figure 13.** Measuring position with feeler gauge.

### 9.1 Measuring the air gap

The brake must be installed correctly. This measurement must be made with the coils unpowered.

Insert a feeler gauge between the split main pressure plate (1) and the coil housing (4) (see Figure 12), and measure the air gap. The positions in which the air gap must be measured are indicated in Figure 13. Compare the value measured with the correct air gap values indicated in Table 1.

### 9.2 Testing brake aperture

Power the coils electrically or use the manual release procedure (tightening the release screws or using the release lever).



**ATTENTION!**

When released manually with the release screws, the brake is held permanently in the open state. Before using the installation again, return the release screws to their original positions and check that the brake engages correctly (see Chapter 11).

### 9.3 Checking state of brake discs after emergency braking

As the brake normally serves as a holding brake, the friction material is not subject to wear. The normally very durable friction material is only subject to wear in the event of emergency braking.

In case of excessively frequent emergency braking, the travel of the disc brakes (6 see Figure 1, Figure 2, Figure 3 and Figure 4) may increase, increasing the noise produced by the brake.

**Always check the condition of the brake after any emergency braking usage, to evaluate the state of wear of the friction material of the brake discs. Once the size of the air gap exceeds the values indicated in Table 1, the installation must be put out of service and the correct value must be restored by adjusting the air gap itself (paragraph 10.1) or replacing the brake disc (paragraph 10.2).**

## 10 - INSTRUCTIONS FOR EXTRAORDINARY MAINTENANCE



**ATTENTION!**

The operations described as follows alter the functional characteristics of the brake and may cause a reduction in or complete loss of braking torque!  
**RISK OF UNCONTROLLED MOVEMENT!**  
Before starting any work, take all measures necessary to make the installation and the machine safe in accordance with applicable legislation.

See Paragraph 5.1 for the figures illustrating the components involved

### 10.1 Instructions for adjusting air gap

The air gap of the brake is set in the factory to values within the range indicated in Table 1. When the friction material is worn (e.g. after numerous emergency braking events), the brake may become noisy or there may be a loss of braking performance.

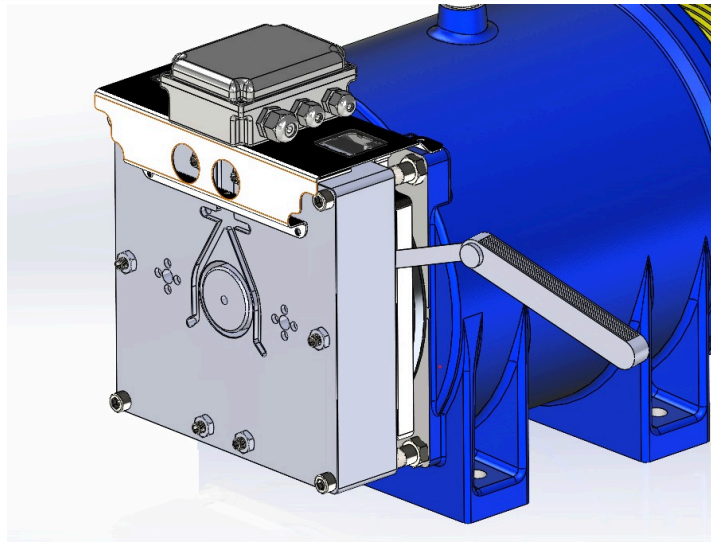

Figure 14. Feeler gauge (centil) used to adjust the brake

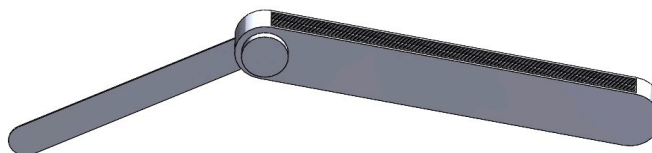
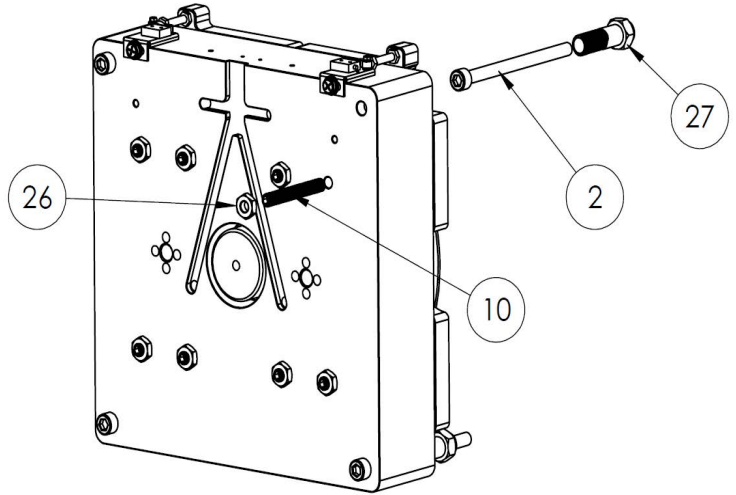
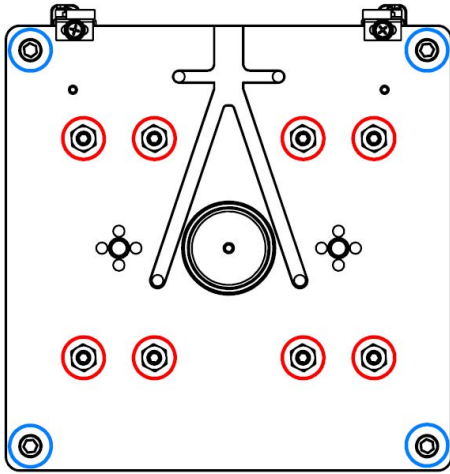

Figure 15. Feeler gauge





The air gap from the points (mirrors) of the centil and the machine in **Figure 13** is checked according to the values given in **Table 1**. If the air gap does not comply with the values in table 1, the following actions are taken. Air gap adjustment procedures are illustrated in **Annexe A**.

#### 10.1.1. Reducing the air gap

The air gap is reduced by tightening the brake adjustment screw counterclockwise and the brake fixing screw clockwise millimetrically. It is checked again at the points in **Figure 13**.

#### 10.1.2. Increasing the air gap

The air gap is increased by loosening the brake adjustment screw clockwise and the brake fixing screw counterclockwise by millimeters. It is checked again at the points in **Figure 13**.

#### 10.1.3. Noise adjustment that may occur after air gap adjustment

A lining noise may occur after air gap adjustment. The procedures to eliminate this noise are illustrated in **Annexe C**.

On AEMFX brakes, the feeler gauge (centil) are installed between the coil housing (1) and the pressure plate (4). The brake is adjusted at the factory to an air gap in the range specified in **Table 1**. If the friction material is worn, the correct air gap value should be restored with a feeler gauge.



#### ATTENTION!

Take all measures necessary to make the lifting installation safe before starting any work on the installation. Secure all suspended loads. Apply suitable "Work in progress" warning signs and other devices to the installation. If the brake is equipped with an encoder, make sure that it is possible to carry out the tuning procedure before starting maintenance work.



#### ATTENTION!

Disconnect electrical power before starting any maintenance work.



#### ATTENTION!

After any adjustment made to the air gap of the brake, check that, during normal operation, the brake discs move freely without excessive dragging, which may cause overheating, accelerated wear of the friction material of the brake discs and a rapid loss of braking performance.

### 10.2 Replacing brake assembly on machine, or replacing brake discs.

The brakes produced by **AKIŞ Elevator** are normally supplied fully assembled and ready for use.

If it is necessary to replace any components of the brake, contact the technical support service ([servis@akisasansor.com.tr](mailto:servis@akisasansor.com.tr)). In relation to the nature of the defect, **AKIŞ Elevator** will provide you with the same brake type as a partially assembled spare part, or with the brake discs necessary. The procedures for replacing the brake assembly or the brake discs are illustrated in **Annexe B**.



#### ATTENTION!

Take all measures necessary to make the lifting installation safe before starting any work on the installation. Secure all suspended loads. Apply suitable "Work in progress" warning signs and other devices to the installation. If the brake is equipped with an encoder, make sure that it is possible to carry out the procedure for synchronising the encoder before starting maintenance work.



#### ATTENTION!

Disconnect from the power supply by turning off the main switch before starting any work on the machinery of the lift installation. Make sure that no part of the machinery is powered during the replacement work.



**ATTENTION!**

After completing the procedure, make sure that the manual release mechanism used is returned to the operating position! When tightened, the release screws hold the brake permanently open. Unscrew the two release screws (21) until they are 1 mm away from the coil housing (4).

**10.3 Adjusting the microswitches**



**Tools necessary:**

- 2 x 6 mm open end wrenches – **AEMFX brakes;**

To adjust each microswitch:

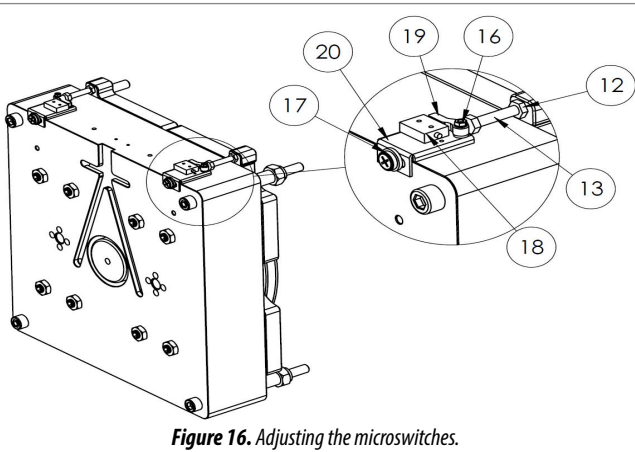

Figure 16. Adjusting the microswitches.

- Power the brake electrically.
- Loosen the adjustment nut (12);
- Tighten the set screw/dowel (13) until the NO contact closes.
- Tighten the adjustment nut (12) without altering the angular position of the set screw (13).

**Note:** After adjusting, check: that the NO contact is closed when the brake is powered; that the NO contact is open when the brake is unpowered.



**ATTENTION!**

- Before putting the installation definitively into service, check that the microswitches switch state correctly when the brake is controlled.
- The microswitches of the brake are part of the safety circuit and must be connected in accordance with the specifications indicated by the manufacturer of the control panel.
- The signals from the two microswitches must be managed separately.

**11 - EMERGENCY PROCEDURE: MANUAL BRAKE RELEASE**

In an emergency, the brake may be released with a mechanical procedure even if there is no power supply. As standard, the brake is equipped with a manual release mechanism consisting of release screws (paragraph 11.1). See Paragraph 5.1 for the figures illustrating the components involved.



**ATTENTION!**

The manual brake release procedure must only be used by authorised and qualified personnel.

**11.1 Manual brake release procedure with release screws (standard version)**

The manual release procedure consists of using the two release screws (21) directly. These screws are identified by yellow labels with English text applied to the rear of the coil housing (4), which describe the safety function performed by the screws.

The two release screws (21) have a coarse pitch metric thread of 1.75 mm per turn. Each release screw works independently for one of the two halves of the brake.

During normal operation of the machine, the two release screws (21) are not tightened, and there is a gap of approximately 1 mm (factory setting) between the end of each screw and the coil housing (4).

To avoid unintentional maneuvers, the 2 release lever were fastened to the sides by means of a rope.

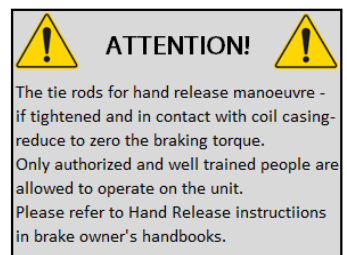

Fig.17. Label with notice relative to manual release procedure with release screws.



**Annexe D** contains the procedure necessary for releasing the brake manually with the release screws.



**ATTENTION!**

When tightened, the two release screws (21) hold the brake permanently open, allowing the traction sheave to rotate freely!  
Handle with care! Be aware of uncontrolled movements of the car.



**ATTENTION!**

Disconnect electrical power before starting any maintenance work.

### 11.2 Manual brake release procedure with release levers (optional)

As an optional accessory ordered together with the brake or purchased subsequently, the brake may be equipped with a manual release lever mechanism. These levers are identified by yellow labels with English text applied to the rear of the coil housing (1), which describe the safety function performed by the levers. Each release lever works independently for one of the two halves of the brake.

**Annexe E** contains the procedure necessary for releasing the brake manually with the release levers.

**Annexe E** contains the instructions for installing the release levers on a brake in standard configuration already equipped with manual release screws.

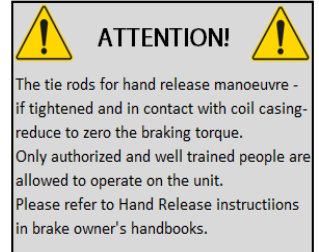

**Fig.18.** Label with notice relative to manual release procedure with release levers.



**ATTENTION!**

Disconnect electrical power before starting any maintenance work.

## 12 - THE BRAKE AS A SYSTEM PROTECTING AGAINST UNCONTROLLED MOVEMENT OF THE CAR

### 12.1 Introduction

The safety brake may be used as a device to arrest the car for testing the conformity of the lift installation with the specifications requested by the standard EN 81-20:2014.

The safety brake is a link in the chain of safety required by the standard to prevent uncontrolled movement of the car. The emergency situation considered concerns the failure of any component of the machine or of the device governing the speed of the lift which results in uncontrolled movement of the car starting from the parking position at a floor, and with the door unlocked or with the car door open as the car exits the door unlock zone. In this situation, the car is subject to uniformly accelerated upward or downward (not controlled by motor) movement influenced by imbalance, the efficiency of the shaft and the inertia of the installation as a whole.

The arrest time and distance depend on the detection distance defined for the uncontrolled car movement detection system, the time lag introduced by the electrical control panel and the characteristics of the braking device. A detector must be capable of detecting uncontrolled movement of the car before the car exits the door unlock zone. The detector signals the emergency condition to the control panel which, albeit with its own inherent time delay, must cut off power to the emergency brake.

This system must be capable of behaving as requested with no input or support from the components of the lift which, during normal operation, are responsible for controlling car speed and arresting the car, unless the braking device in question is a redundant system and is monitored automatically to ensure correct operation.

Conformity with the requested specifications of the standard must be verified for each component of the safety chain and for the entire lift installation.

### 12.2 Definition of key parameters required by applicable standard/directive for intended application

All the brakes described in this manual may be used as service and/or emergency brakes on gearless machines (see Paragraph 3). In the case of gearless machines, the brake is the only braking device equipping the machine and therefore serves both functions. As a result, monitoring is necessary to verify that the mechanism opens and closes correctly and ensure the redundancy requested by the standard.

In applications on gears, this brake serves solely as an emergency brake, as winches are equipped with a service brake on the fast shaft acting as the redundant system required by the standard.

On the basis of these considerations, the most appropriate model of brake for each machine may be defined in relation to the function/s served by the brake itself to ensure compliance with the applicable standards and directives. In applications where the brake serves both service and emergency brake functions, each individual brake must be sized appropriately to be capable of producing a braking torque at least double the torque produced by the installation braked. Half the static braking torque of the brake must be sufficient to prevent the car from moving from the parking position at the floor in the event of failure or malfunction of one of the two independent parts of the braking device. In applications as an emergency brake only, each individual brake may be sized to produce a braking torque equal to the torque produced by the installation braked, as redundancy is ensured by the service brake installed on the fast shaft of the winch.

Paragraph 5.2 summarises all the technical characteristics of the brakes, indicating the certified minimum braking torque and response time values for each brake.

The tests conducted on each brake considered the worst possible scenario, however, with no additional braking torque produced by other devices to assist the braking of the braking device tested.

### 12.3 Interfacing instructions

As indicated in paragraph 12.1, conformity with the specifications requested by the standard EN 81-20:2014 must be verified for each component in the safety chain and for each individual lift installation. This paragraph contains the instructions for interfacing the brake with the other components constituting the system protecting against uncontrolled movement of the car, as required by the standard EN 81-20:2014.

### 12.4 Uncontrolled car movement detector

"Uncontrolled movement" of the car is defined as upward or downward movement of the car (depending on the state of imbalance of the installation) which is not controlled by the machine, occurring as a result of a fault of any component of the machine itself or of the lift speed governor device. An uncontrolled car movement detector for both upward and downward movement must be installed on each floor in the lift shaft at a distance from the level of the floor not exceeding the limit of the door unlock zone (paragraph 5.6.7.7 of the standard EN 81-20:2014). These sensors must be located at a distance from the level of the floor not exceeding  $\pm 200$  mm.

### 12.5 Control panel

The detector detects uncontrolled movement of the car and transmits a signal indicating the emergency condition to the control panel. The control panel must generate a control signal, within the shortest time possible, which cuts off electrical power to the emergency brake for arresting the car. The inherent delay introduced by the control panel must not exceed 100 ms.

### 12.6 Cutting off electrical power supply to brake

The electromagnetic brake receives DC electrical power at its rated voltage. To minimise the closure time of the brake in the emergency situation considered, **the DC power supply to the brake (after the rectifier circuit) must be cut off in a position as close as possible to the coils of the brake.**

### 12.7 Monitoring functions for microswitches (for usage as service / emergency brakes on gearless machines)

The brake is equipped with two microswitches (one for each primary pressure plate) situated on the exterior of the structure of the coil housing, which confirm the effective mechanical aperture and closure of the pressure plates themselves (see Paragraph 7.3).

In applications where the brake serves as both a service brake and an emergency brake on gearless machines, the states of both microswitches must be monitored continuously during all opening and closing operations of each pressure plate. If a pressure plate does not respond as required to the command signal sent to the brake, the control system must disable any further operation of the installation and the fault must be signalled. The fault warning signal generated must remain active until the cause of the fault has been identified and resolved by qualified personnel, and the braking device has been restored to proper working order.

## 13 - END OF LIFE SCRAPPING



The brakes are constructed from materials which are not harmful for the environment and are free of asbestos (in compliance with paragraph 0.4.3 of the standard N 81-20:2014). At the end of the service life of the braking device, these materials must be recycled separately in accordance with applicable legislation.

## 14 - FAQ



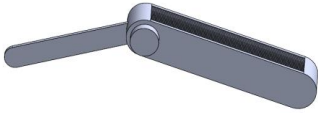
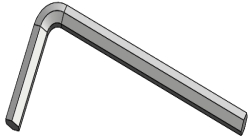
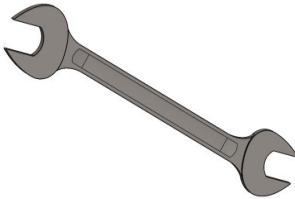

| PROBLEM   | POSSIBLE CAUSE  | SOLUTION   |
|---|---|--|
| Brake does not open   | Power supply voltage too low  | Check rated voltage on data plate of brake   |
|   | One or more coils damaged   | Measure resistance of coils. Contact after-sales service of Akış Elevator to have brake replaced             |
| Brake does not release and inverter in "encoder error" or "overcurrent error" state             | Friction material adhered onto metal surface it is in contact with                | See paragraph 8.1  |
| Excessive noise when brake is closing   | Electrical power to brake is being cut off on the DC side of the bridge rectifier | Cut off power to brake on AC side of bridge rectifier during normal operation                                |
|   | Friction material excessively worn  | See paragraph 10.2, Annexe B   |
| Very long response time during emergency braking  | Electrical power to brake is being cut off on the AC side of the bridge rectifier | Cut off power to brake on DC side of bridge rectifier, in a position as close as possible to the brake coils |
| Microswitches not changing state as expected in response to operation of primary pressure plate | The microswitches are adjusted incorrectly  | See paragraph 10.3   |
|   | The microswitches are damaged   | Contact after-sales service of Akış Elevator to order microswitch replacement kit                            |

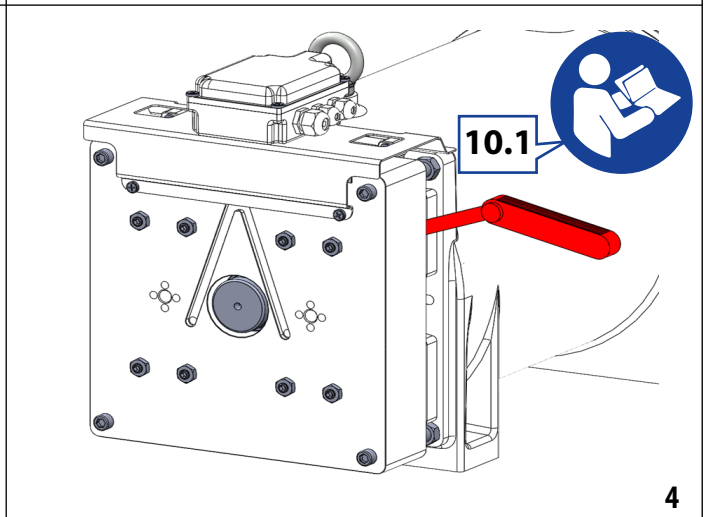
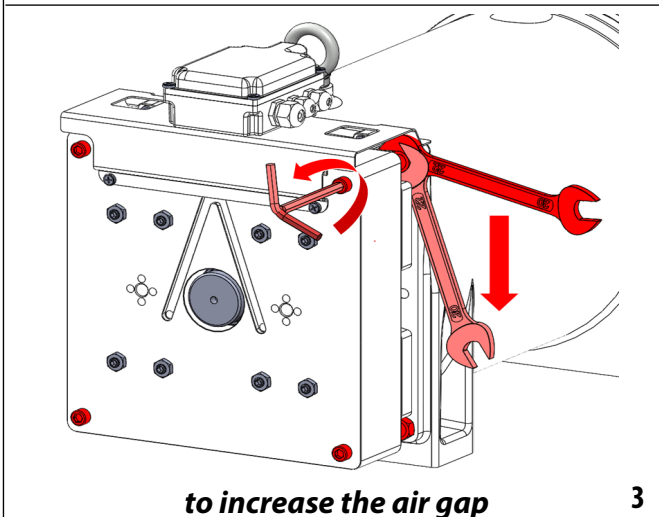
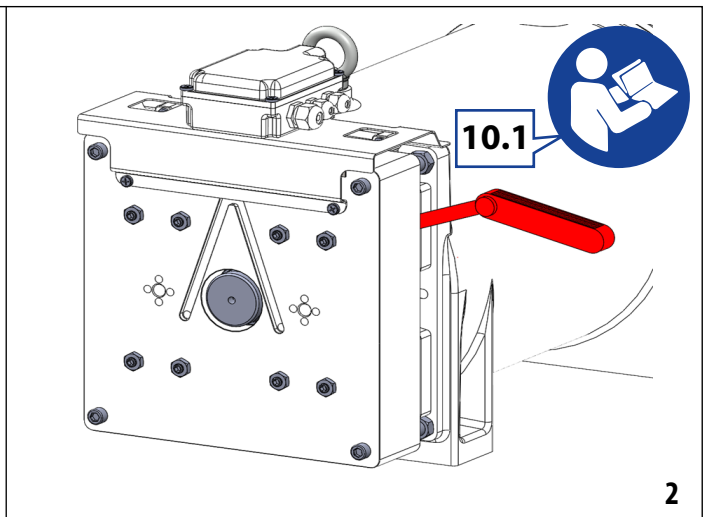
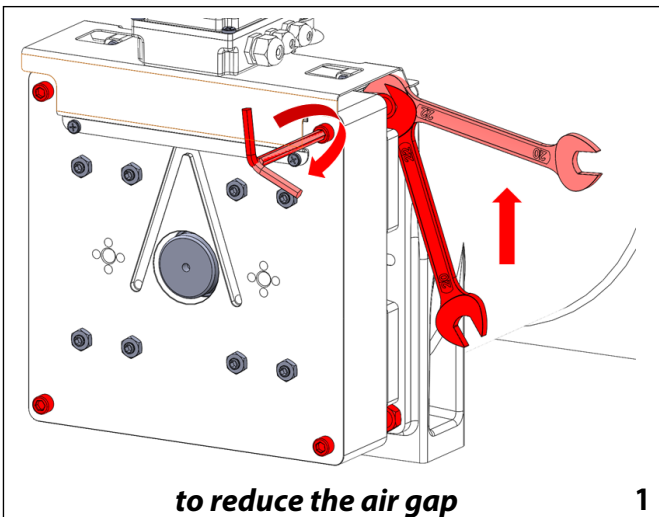
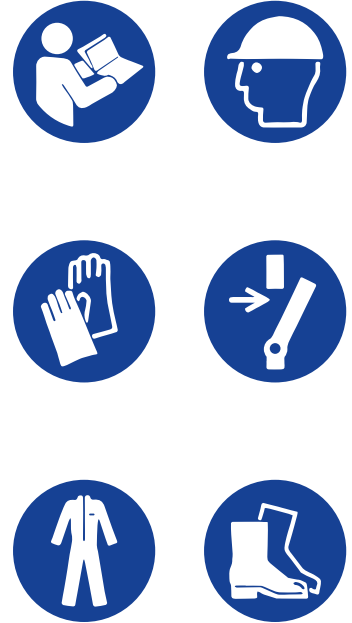
## ANNEX A - HOW TO ADJUST AIR GAP

|    |  |
|----|--|
| 1x |       |
| 1x |  # 8  |
|    |  # 22 |

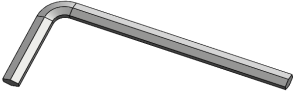
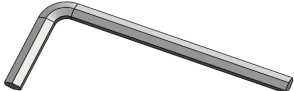
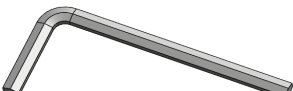
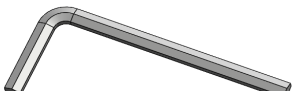

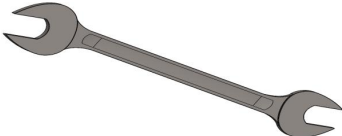
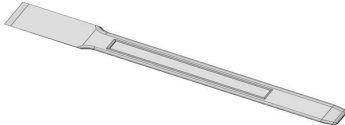
## ANNEX B - HOW TO REPLACE BRAKE DISC

|    |   |  |
|----|---|--|
| 1x |      |  |
| 1x | # 3  | # 4   |
| 1x | # 2  | # 8   |
| 1x |      | # 19  |
| 1x |     |      |
| 1x |    |  |

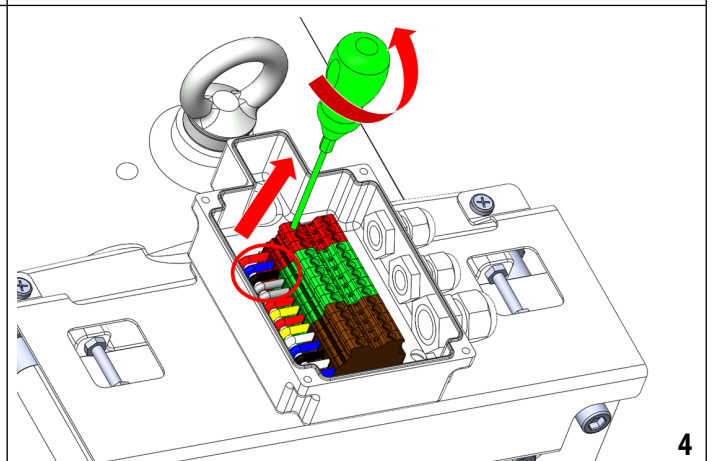
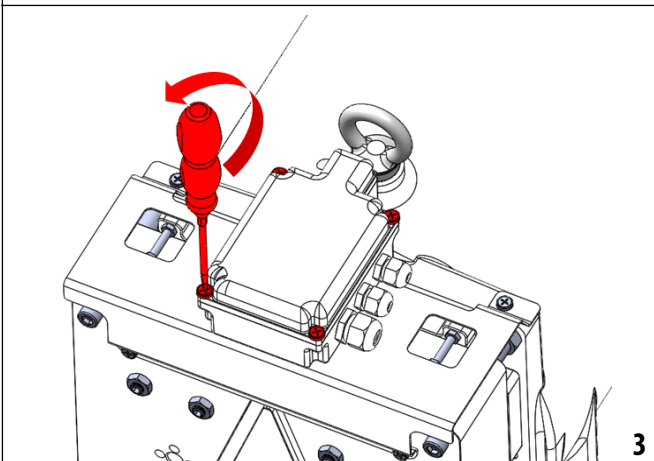
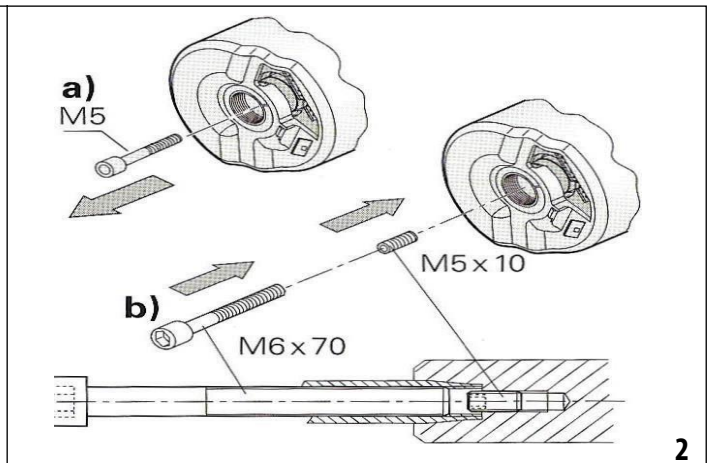
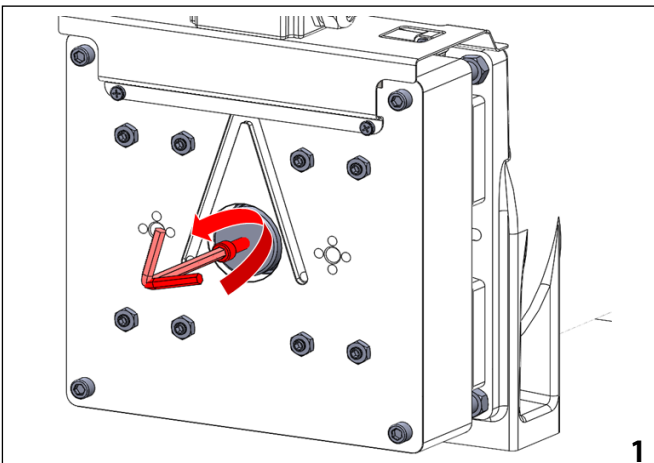
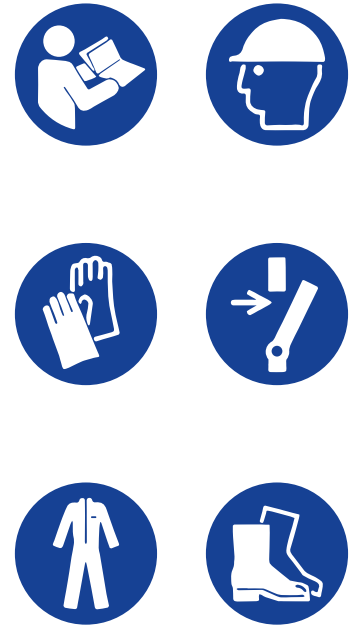

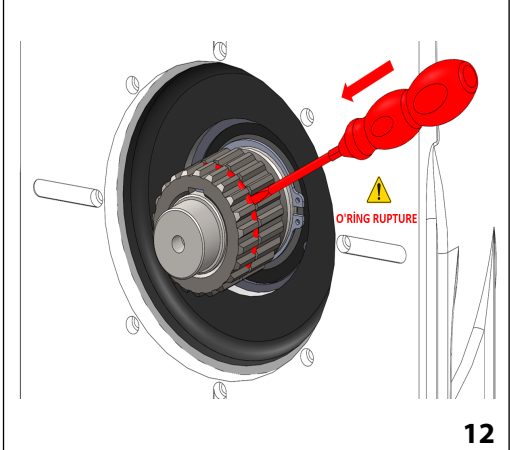
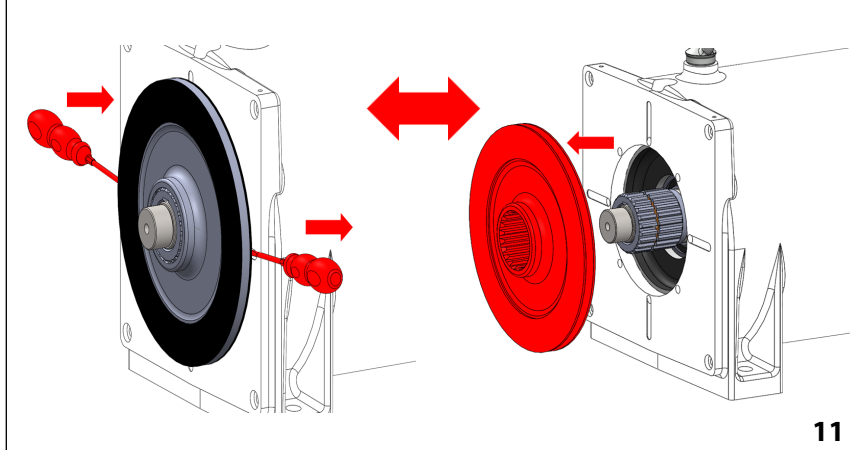
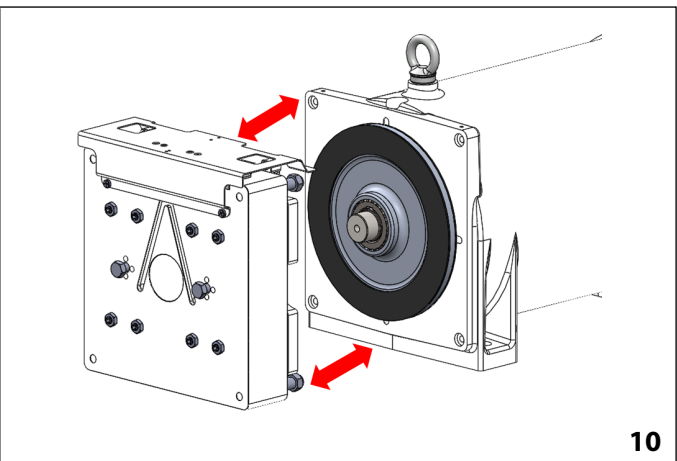
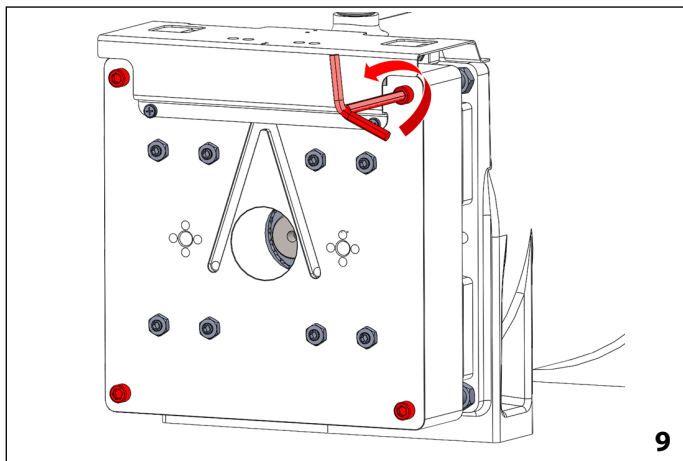
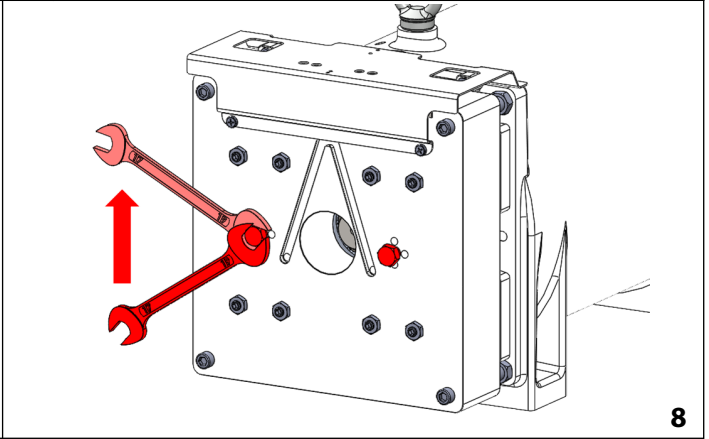
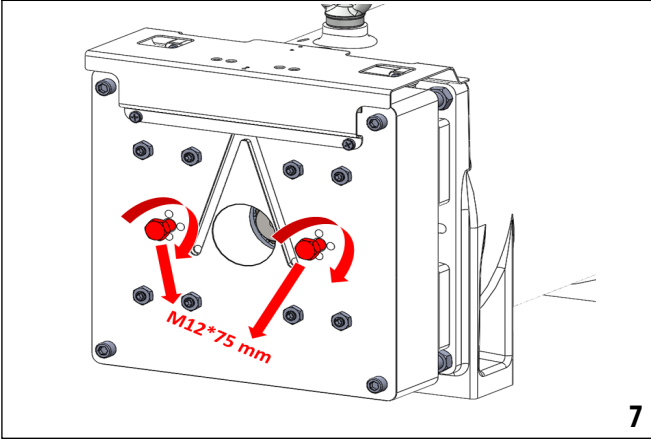
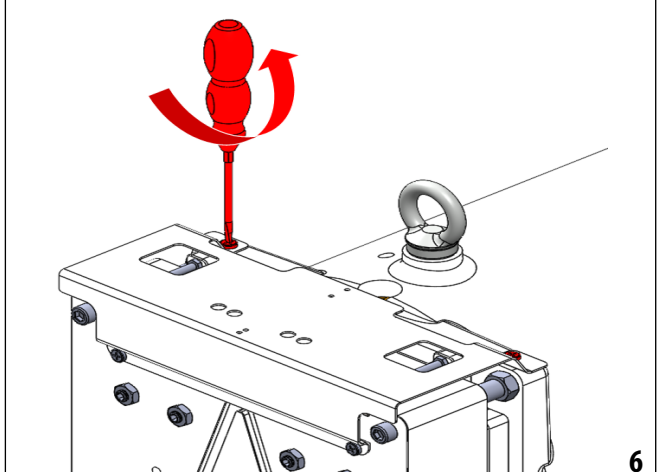
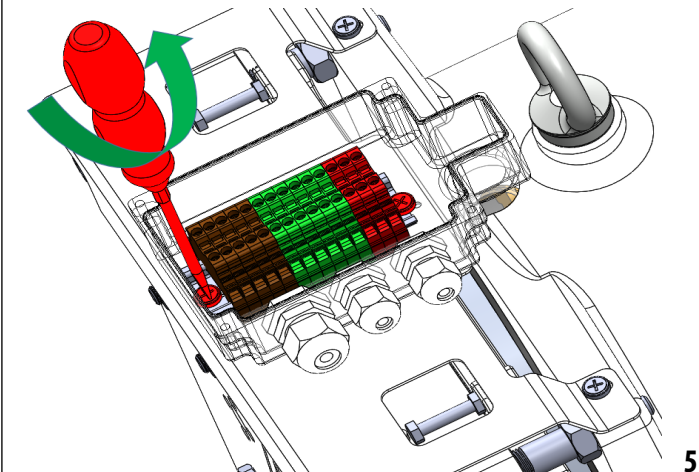



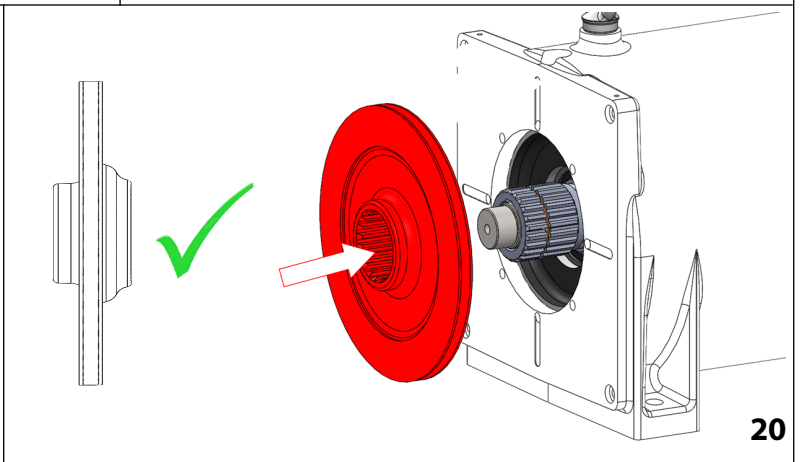
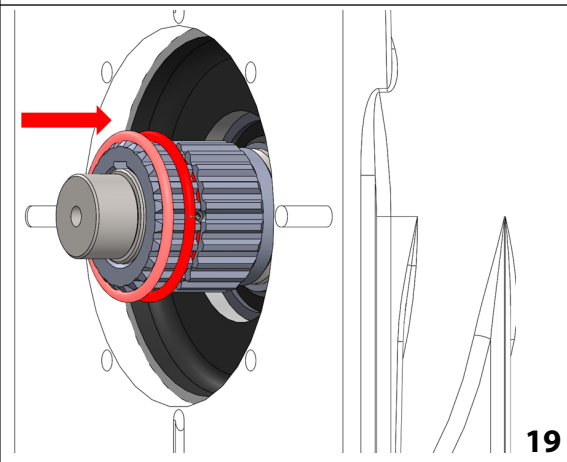
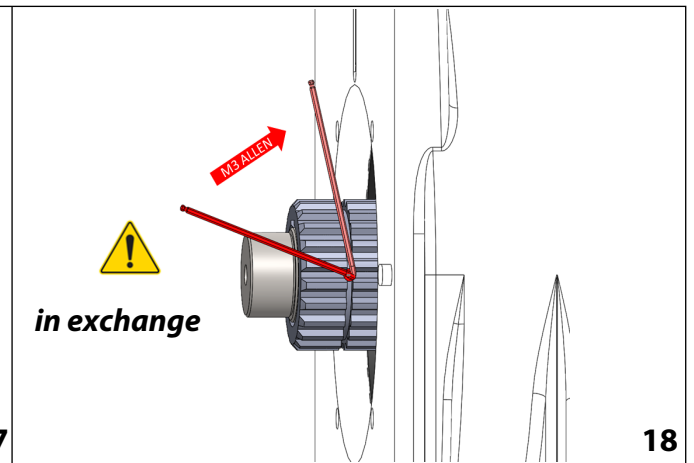
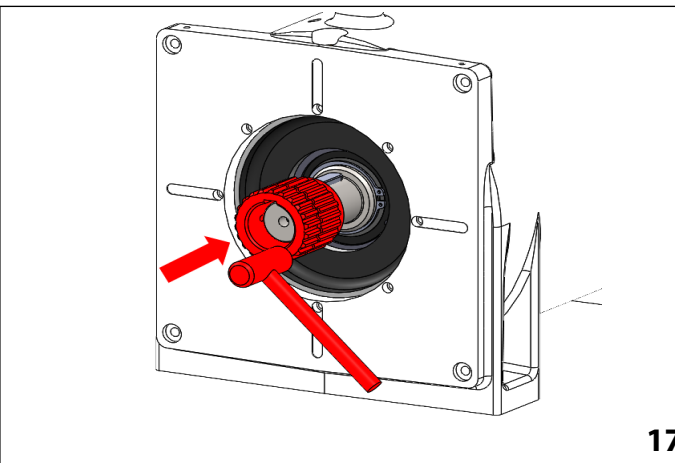
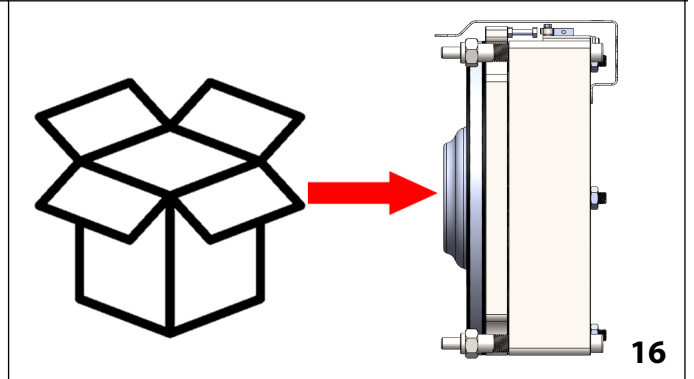
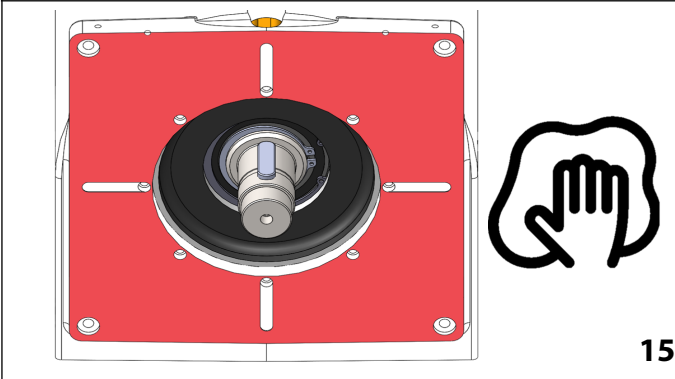
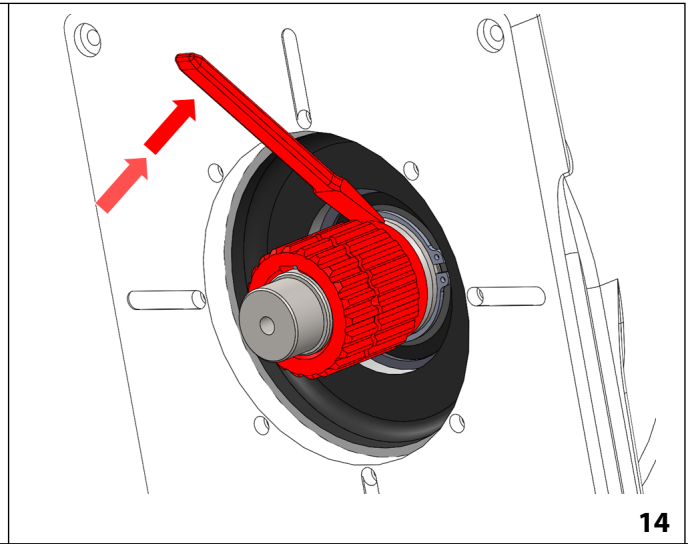
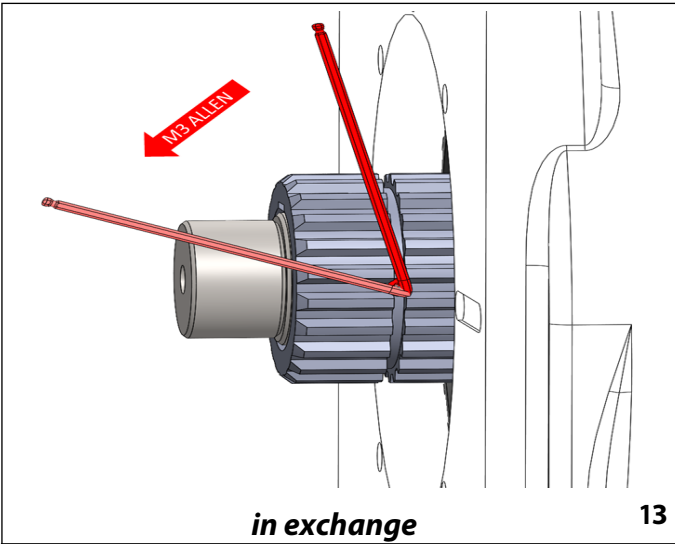

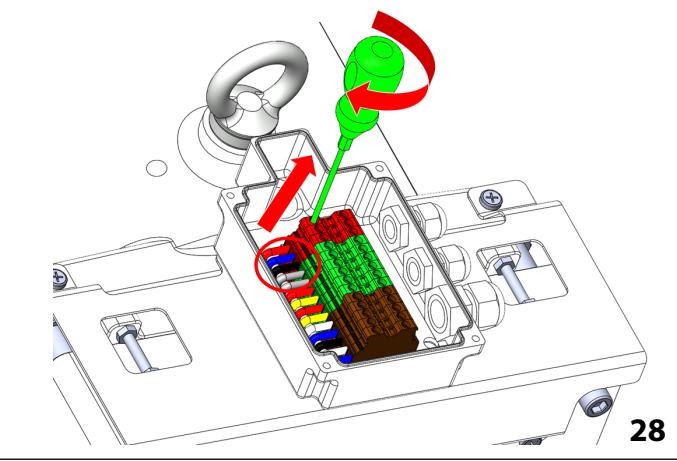
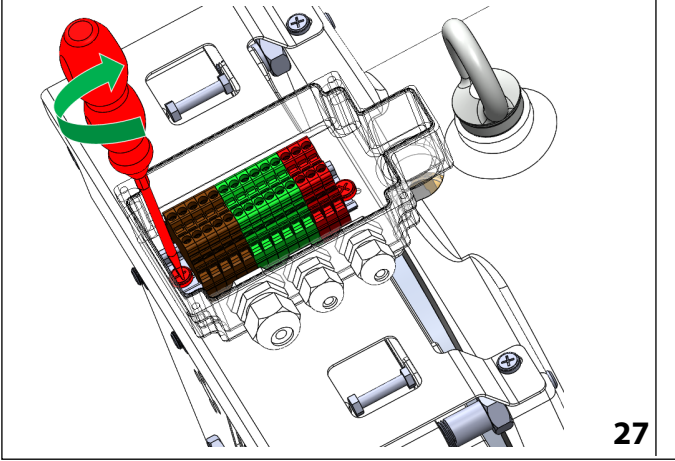
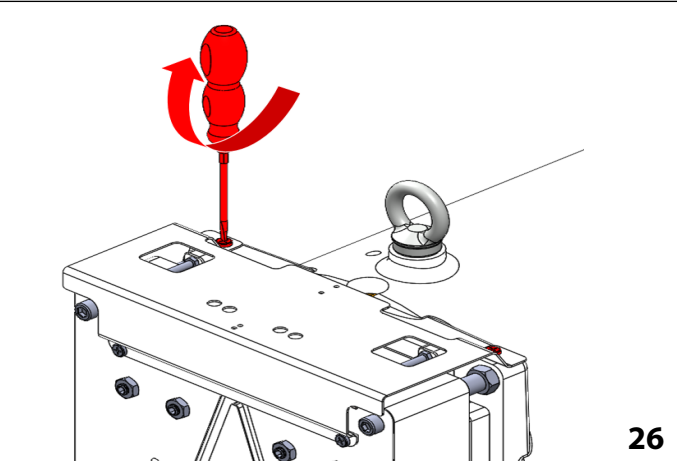
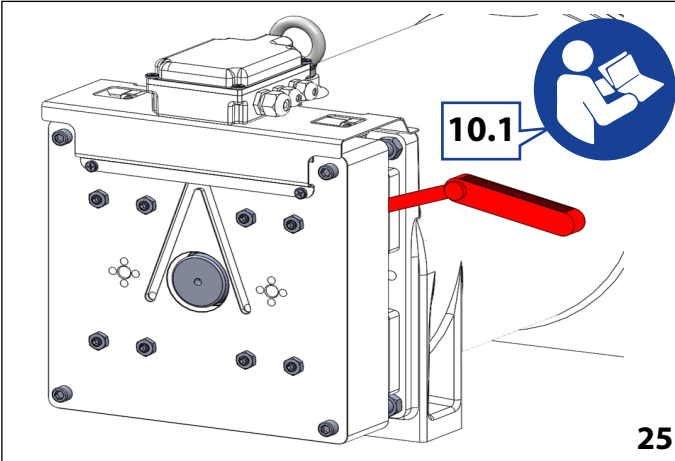
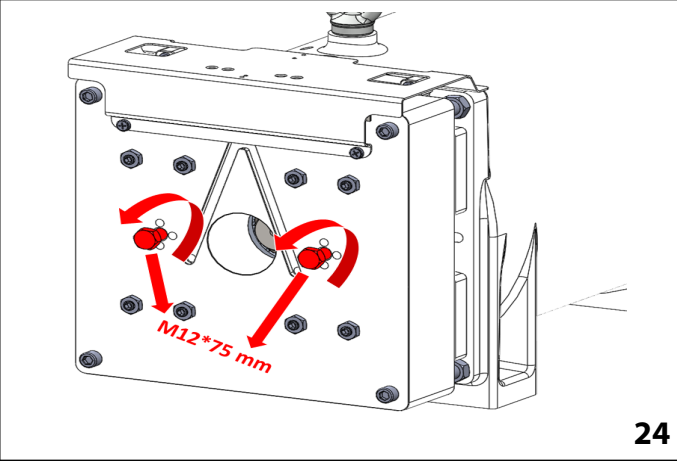
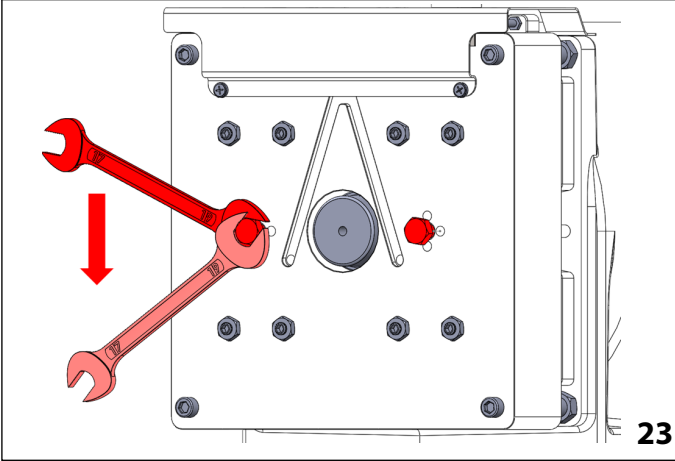
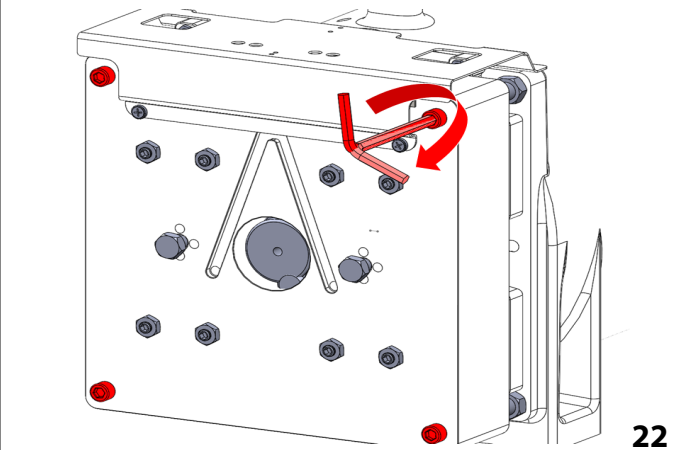
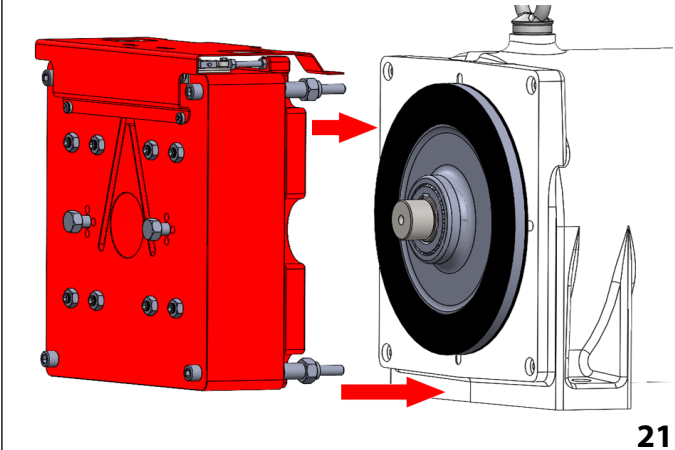



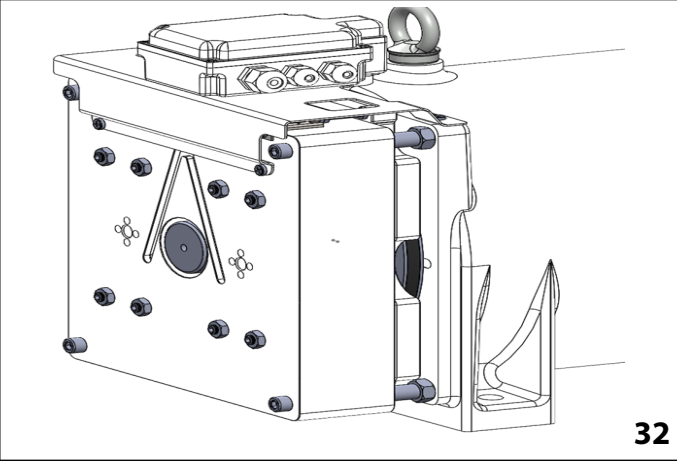
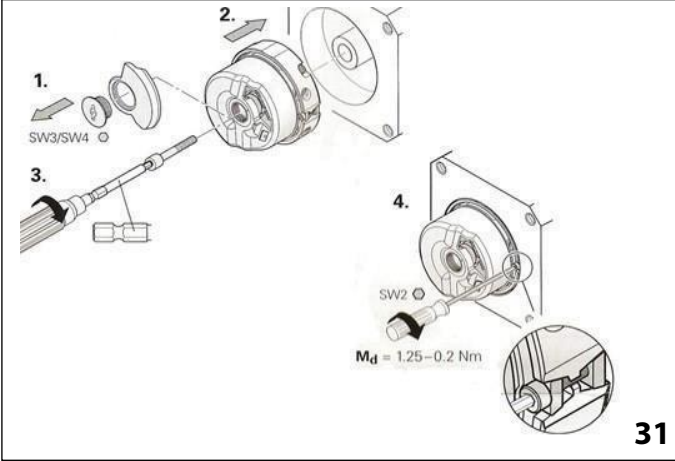
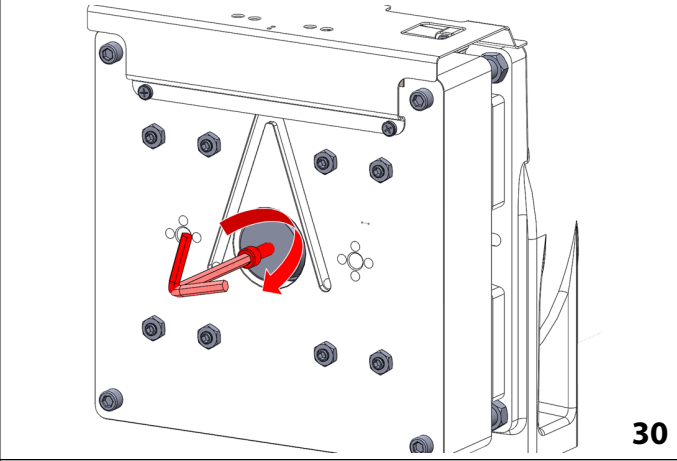
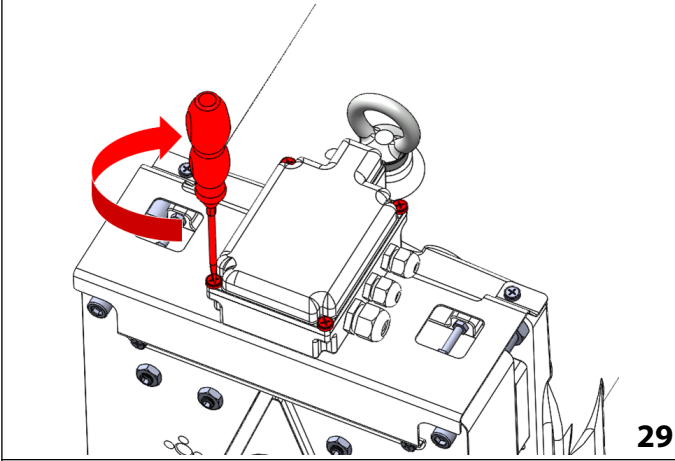

## ANNEX C - HOW TO ADJUST THE NOISE

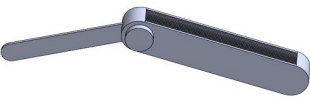
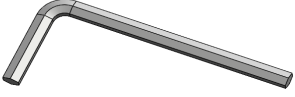
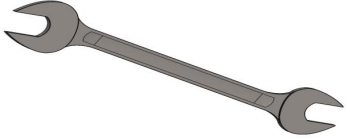
|           |  |   |
|-----------|--|---|
| <b>1x</b> |         |   |
| <b>1x</b> | # 5<br> | # 17<br> |

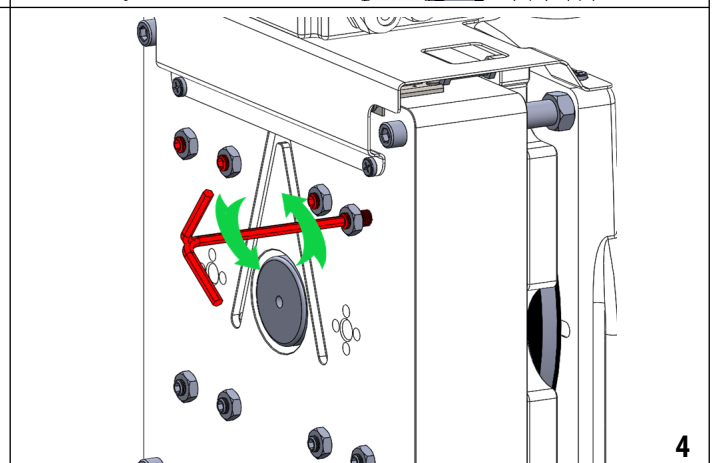
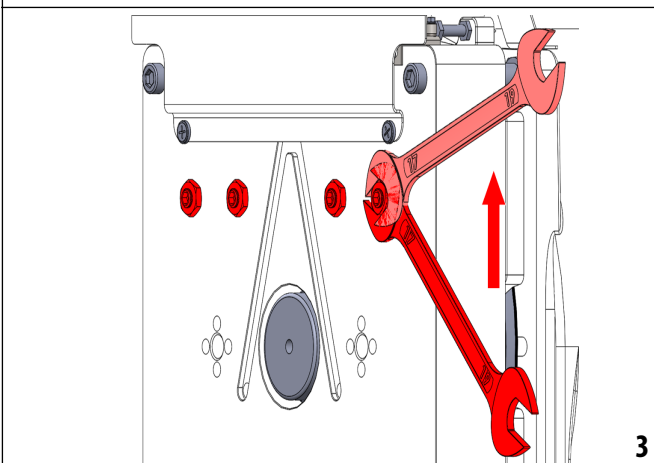
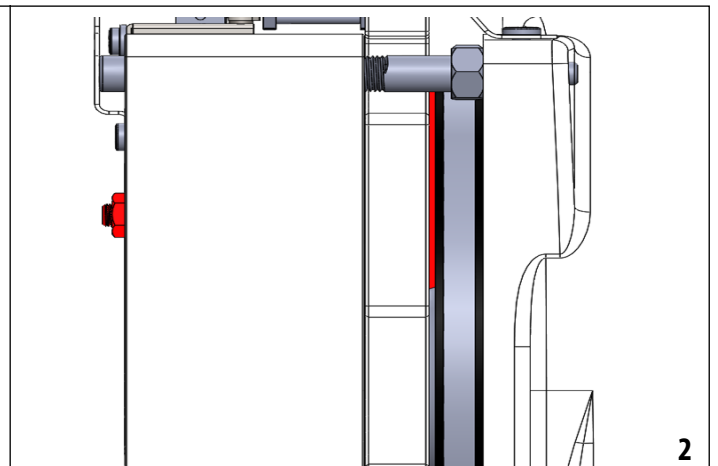
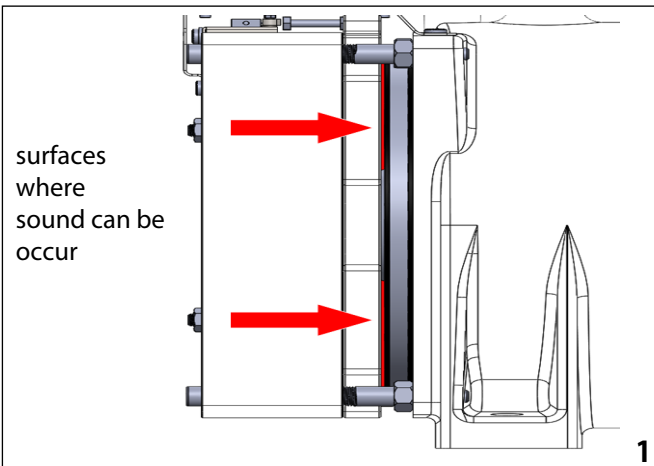

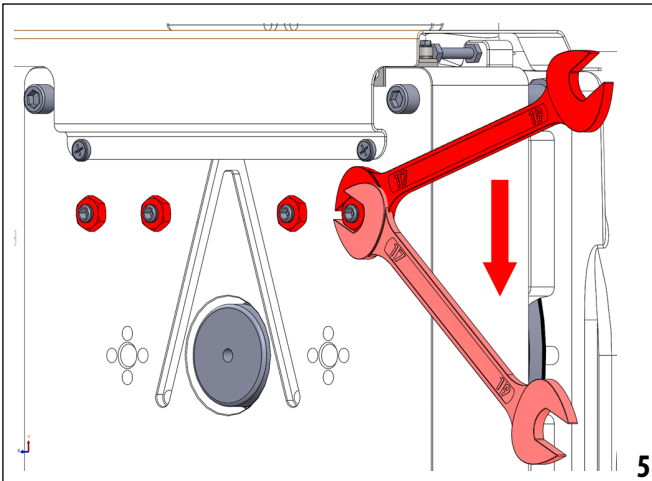

5

surfaces  
where  
sound  
can be  
occur

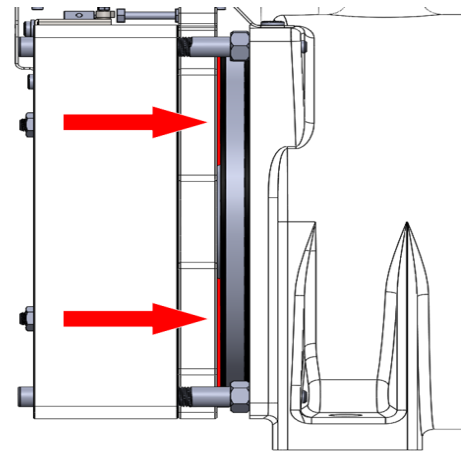

6

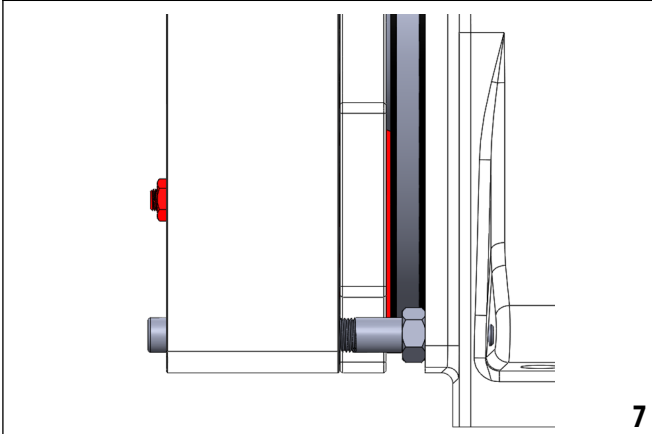

7

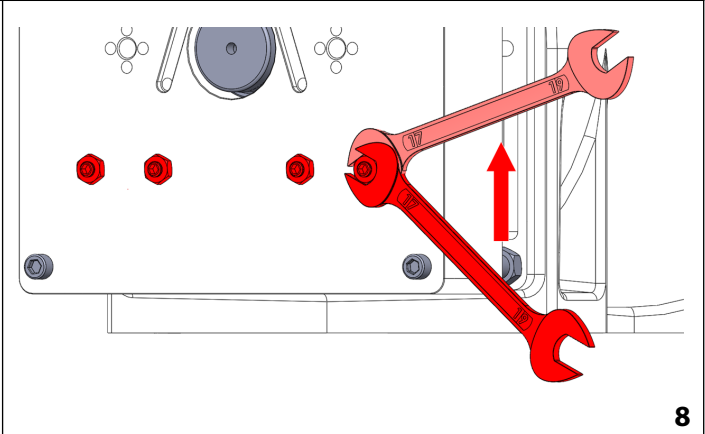

8

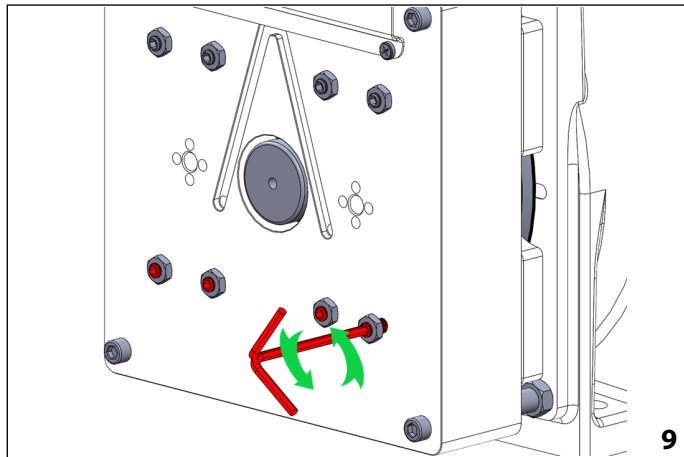

9

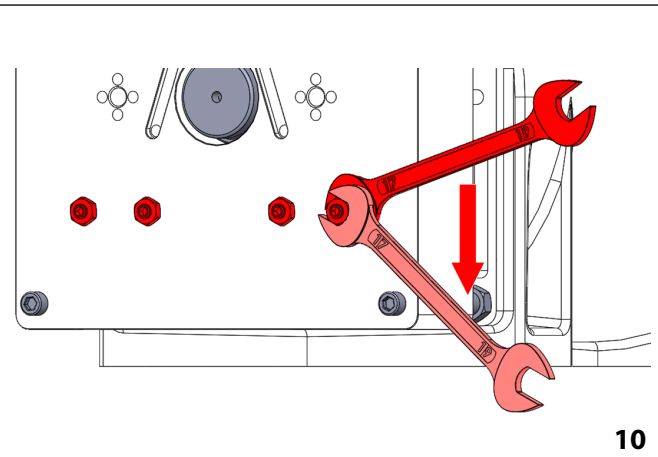

10

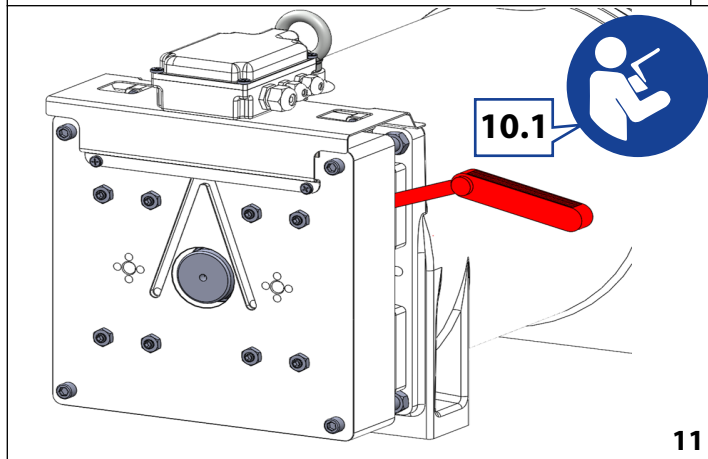

11

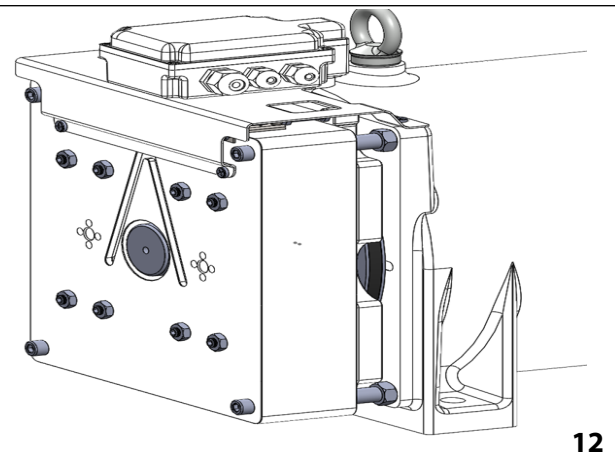

12

## ANNEX D - MANUAL BRAKE RELEASE OPERATION WITH SCREWS

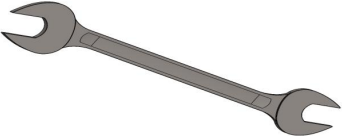
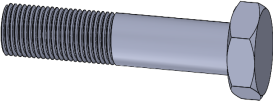
|           |   |                 |
|-----------|---|-----------------|
| <b>1x</b> |  | <b># 19</b>     |
| <b>2x</b> |  | <b># M12*75</b> |



### ATTENTION!

When tightened, the two release screws hold the brake permanently open, allowing the traction sheave to rotate freely! Handle with care! Be aware of uncontrolled movements of the car.

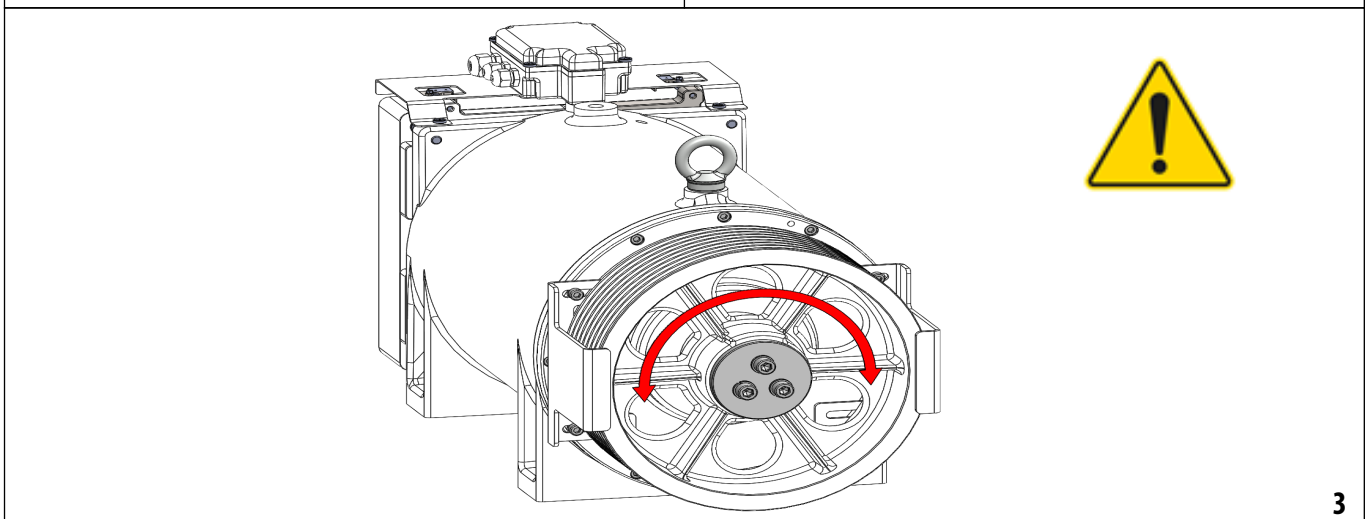
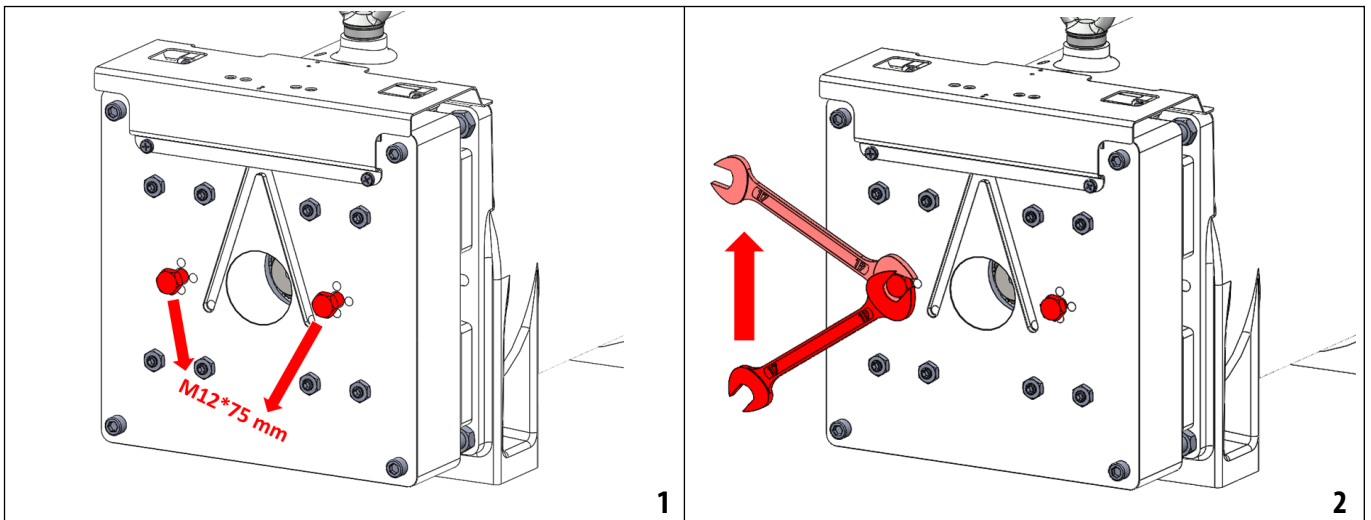

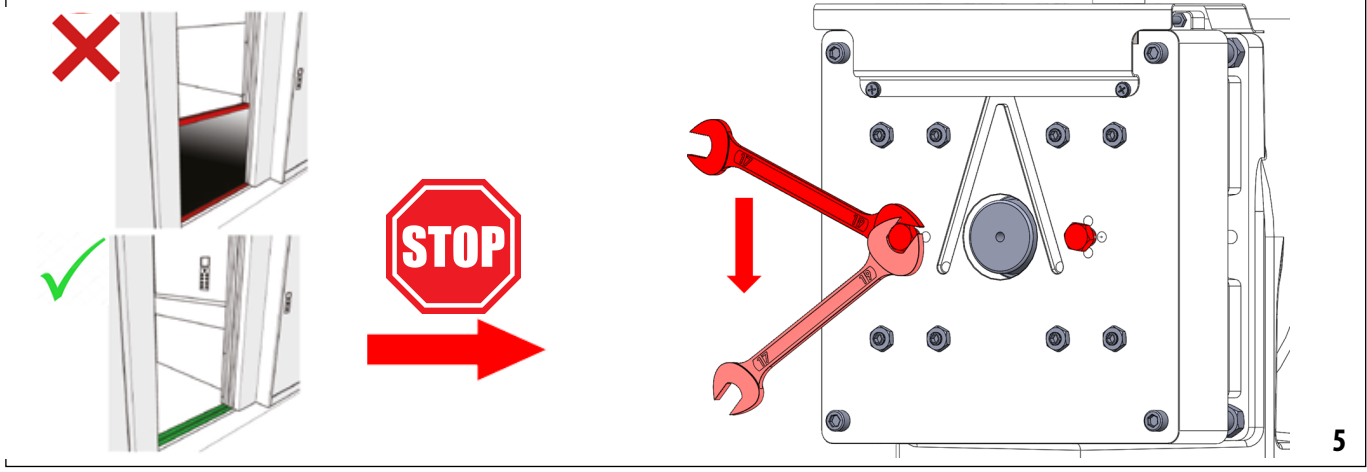
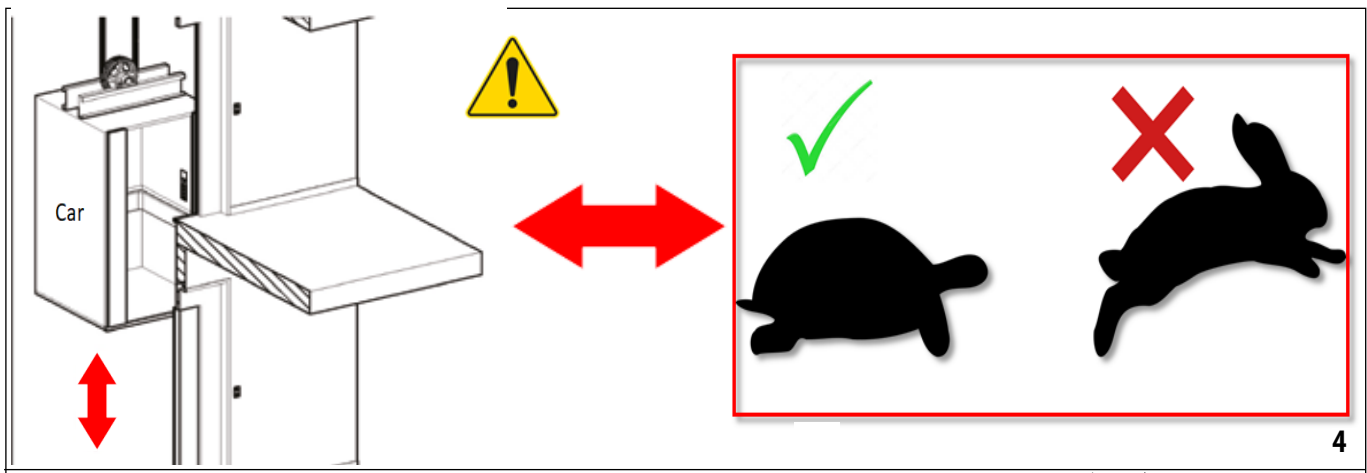

# ANNEX E - HOW TO FIT RELEASE LEVERS - MANUAL BRAKE RELEASE OPERATION WITH RELEASE LEVERS ANHANG

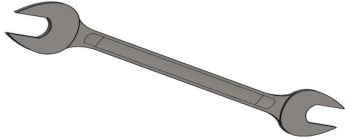
|           |   |             |
|-----------|---|-------------|
| <b>1x</b> |  | <b># 19</b> |
|-----------|---|-------------|



**ATTENTION!**

Having the brake levers facing right or left keeps the brake permanently open, and allowing the traction sheave to rotate freely! Check with care! Be careful of uncontrolled movements of the car.

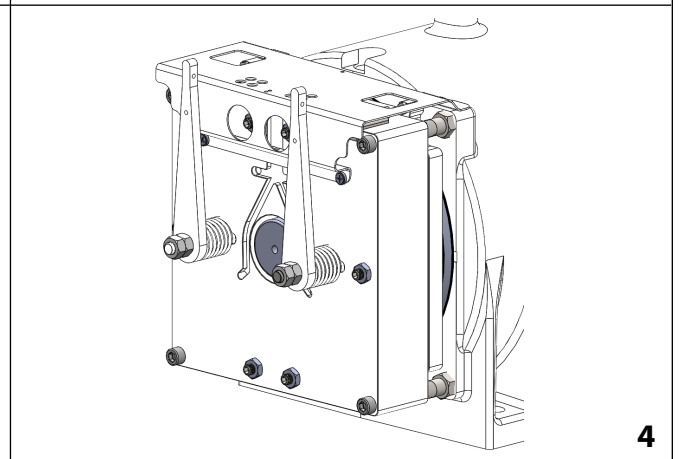
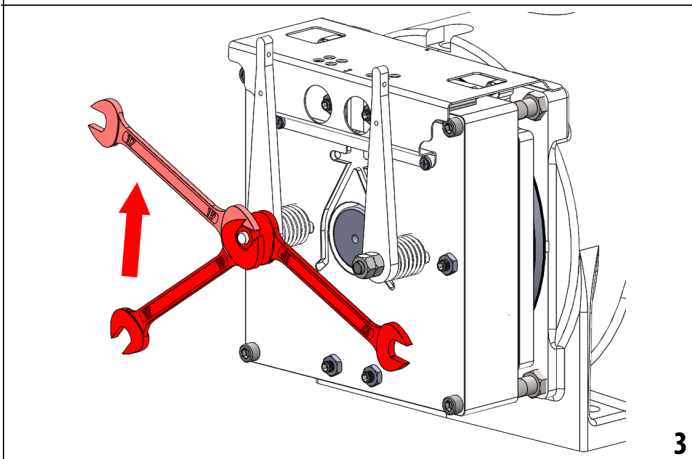
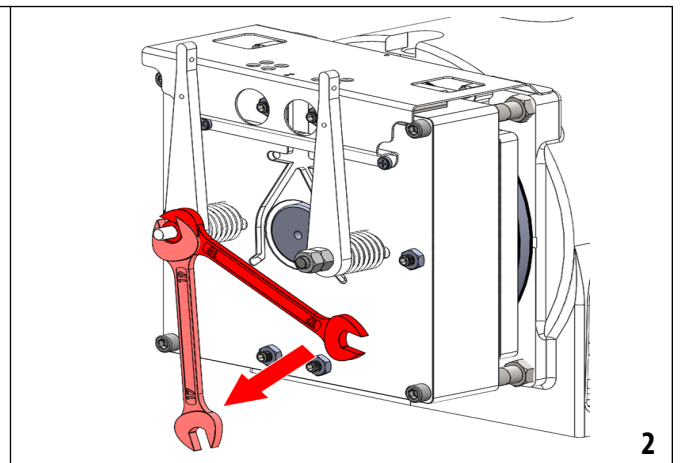
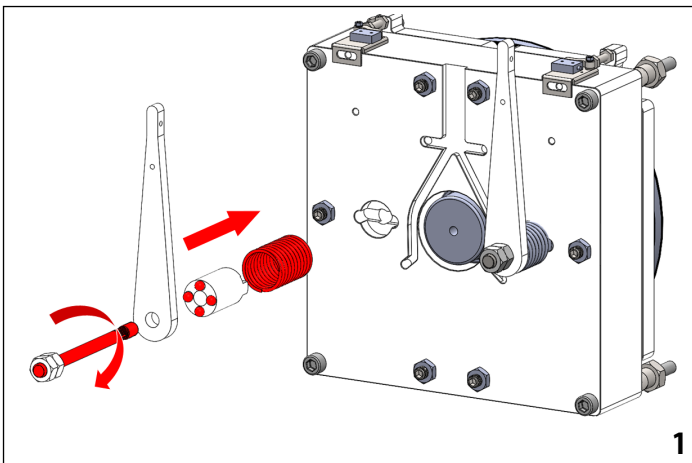

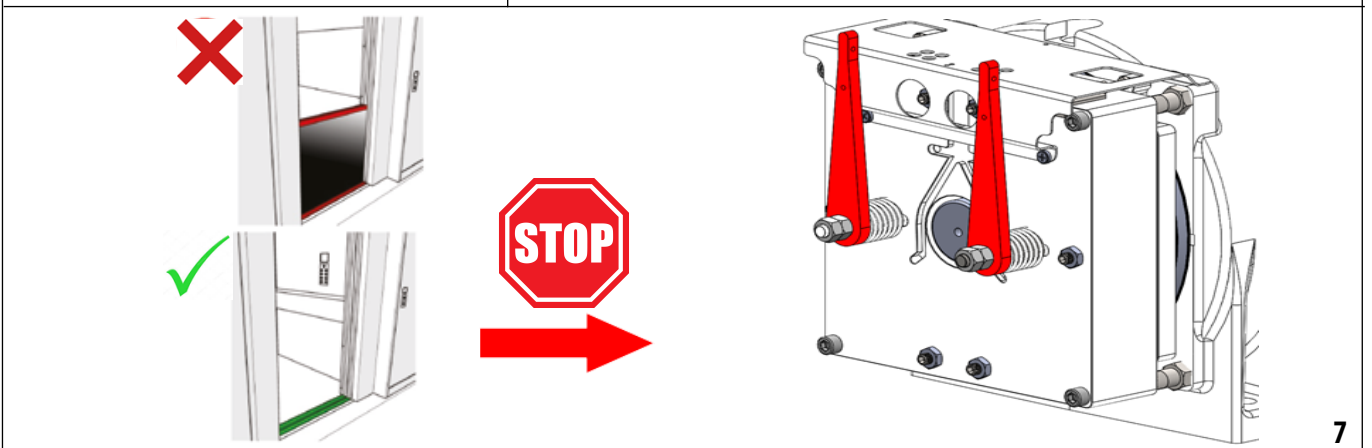
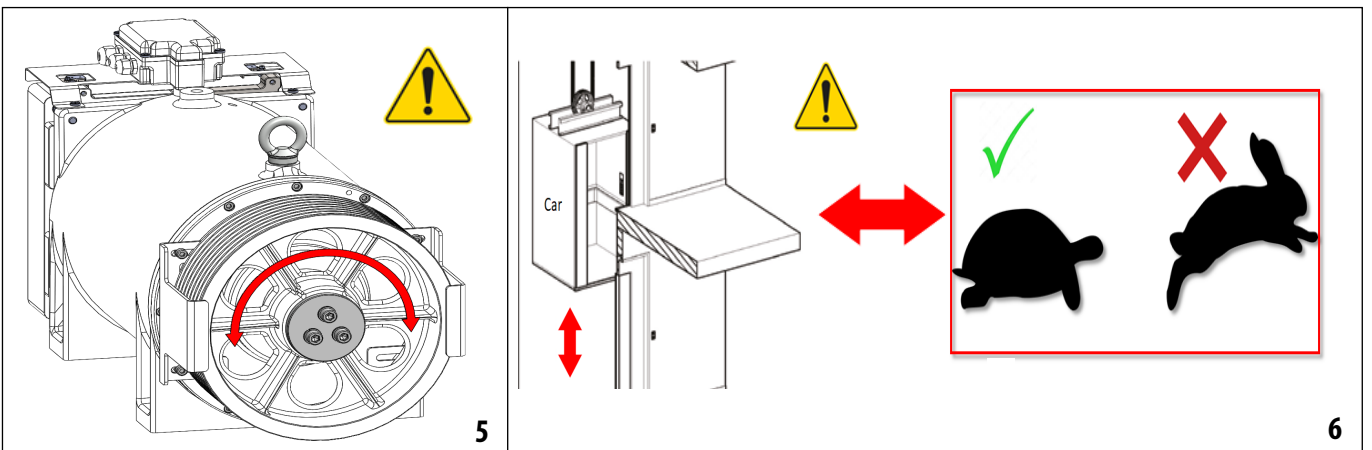
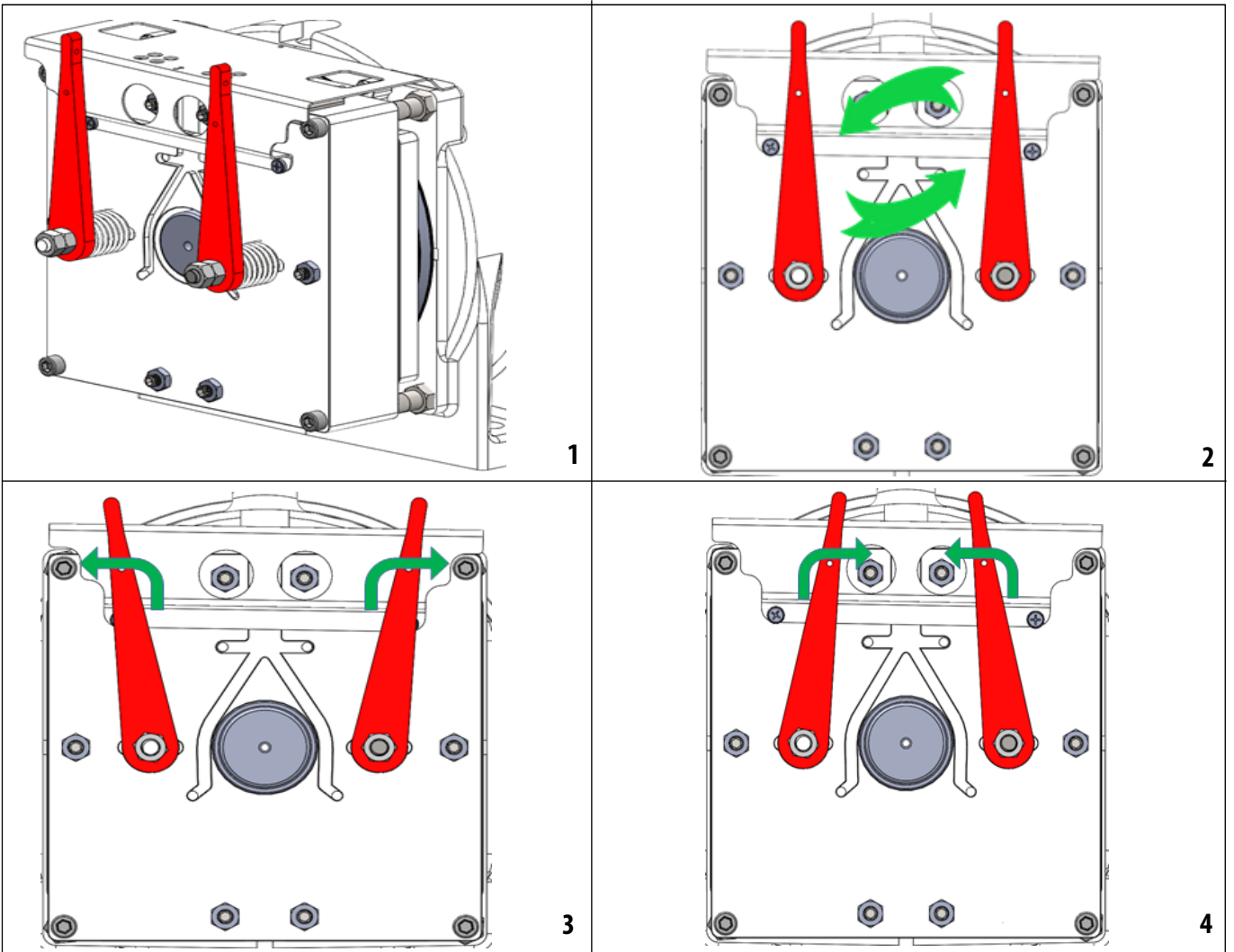





***AKIŞ ELEVATOR MACHINE MOTOR***

***OSB, Kayacık Mah. Ziyaeddin Cad. 6.Sokak No:2 42300***

***Selçuklu/KONYA***

***TÜRKİYE***

***Tel. + 90 (332) 239 07 59 - Fax. + 90 (332) 239 07 29***

***<https://www.akisasansor.com.tr>***

***e-mail: [info@akisasansor.com.tr](mailto:info@akisasansor.com.tr)***